



**NOVELAN**



**OPERATING MANUAL**

**POLARIS**

**AIR/WATER  
HEAT PUMPS**

Indoor installation

[www.novelan.com](http://www.novelan.com)



## Table of contents

1	About this operating manual .....	3	13	Faults .....	22
1.1	Validity .....	3	14	Dismantling and disposal .....	22
1.2	Reference documents .....	3	14.1	Disposal and recycling .....	22
1.3	Symbols and markings .....	3		Technical data / Scope of supply .....	23
1.4	Contact .....	4		Performance curves .....	24
2	Safety .....	4		Dimensional drawings .....	26
2.1	Intended use .....	4		Installation plans .....	27
2.2	Personnel qualifications .....	4		Coastal installation .....	35
2.3	Personal protective equipment .....	4		Hydraulic integration .....	36
2.4	Residual risks .....	4		Polaris 4 with hydraulic station HSV 4 .....	36
2.5	Disposal .....	5		Polaris 4 with hydraulic module HV 4 and buffer tank in series .....	37
2.6	Avoid damage to property .....	5		Polaris 4 with wall-mounted controller WR 4 and separation tank .....	38
3	Description .....	6		Keys hydraulic integration .....	39
3.1	Delivery condition .....	6		Circuit diagrams .....	40
3.2	Layout .....	7			
3.3	Accessories .....	7			
3.4	Function .....	8			
4	Operation and care .....	8			
4.1	Energy-conscious and environmentally- aware operation .....	8			
4.2	Care .....	8			
5	Delivery, storage, transport and installation .....	9			
5.1	Scope of supply .....	9			
5.2	Storage .....	9			
5.3	Transport and unpacking .....	9			
5.4	Installation .....	10			
5.5	Installation of air ducting .....	11			
6	Installing the hydraulic connections .....	11			
7	Electrical installation .....	13			
8	Flushing, filling and venting .....	18			
8.1	Heating water quality .....	18			
8.2	Flush, fill and vent the heating circuit .....	18			
9	Insulate hydraulic connections .....	19			
10	Overflow valve .....	19			
11	Commissioning .....	20			
12	Maintenance .....	21			
12.1	Basic principles .....	21			
12.2	Maintenance after commissioning .....	21			
12.3	Maintenance as required .....	21			
12.4	Clean and flush condenser .....	22			
12.5	Yearly maintenance .....	22			



# 1 About this operating manual

This operating manual is part of the unit.

- ▶ Before working on or with the unit read the operating manual carefully and follow it for all activities at all times, especially the warnings and safety instructions.
- ▶ Keep the operating manual to hand at the unit and hand over to the new owner if the unit changes hands.
- ▶ If you have any questions or anything is unclear, ask the local partner of the manufacturer or the factory's customer service.
- ▶ Note and follow all reference documents.

## 1.1 Validity

This operating manual refers solely to the unit identified by the nameplate (→ "Nameplates", page 7).

## 1.2 Reference documents

The following documents contain additional information to this operating manual:

- Planning & design manual, hydraulic integration
- Installation manual of the flexible air duct system ADH
- Operating manual of the hydraulic unit or the wall-mounted controller
- Operating manual of the heating and heat pump controller
- Brief description of the heat pump controller
- Operating manual of the expansion board (accessories)
- Repair and service instructions for heat pumps with flammable (primary) refrigerant
- Log book

## 1.3 Symbols and markings

Identification of warnings

Symbol	Meaning
	Safety-relevant information. Warning of physical injuries.
	Safety-relevant information. Warning of physical injuries. Flammable materials / flammable (primary) refrigerant

Symbol	Meaning
	Safety-relevant information. Warning of physical injuries. Flammable materials / flammable (primary) refrigerant
	Safety-relevant information. Danger of fatal injury due to electric current.
<b>DANGER</b>	Indicates imminent danger resulting in severe injuries or death.
<b>WARNING</b>	Indicates a potentially dangerous situation, which can result in severe injuries or death.
<b>CAUTION</b>	Indicates a potentially dangerous situation, which can result in moderate or minor injuries.
<b>IMPORTANT</b>	Indicates a potentially dangerous situation, which can result in property damage.

Symbols in the document

Symbol	Meaning
	Information for qualified personnel
	Information for the owner/operator
✓	Requirement for action
▶	Procedural instructions: Single step action prompt
1., 2., 3., ...	Procedural instructions: Numbered step within a multi-step action prompt. Keep to the given order.
	Additional information, e.g. a tip on making work easier, information on standards
→	Reference to further information elsewhere in the operating manual or in another document
•	Listing
	Secure connections against twisting



## 1.4 Contact

Addresses for purchasing accessories, for service cases or for answers to questions about the unit and this operating manual can be found on the internet and are kept up-to-date:

- DE: [www.novelan.com](http://www.novelan.com)
- AT: [www.novelan.at](http://www.novelan.at)

## 2 Safety

Only use the unit if it is in proper technical condition and only use it as intended, safely and aware of the hazards, and follow this operating manual.

### 2.1 Intended use

The unit is designed for household use and is solely intended for the following purposes:

- Heating
- Domestic hot water preparation (optional, with accessories)
- Cooling
- ▶ Proper use includes complying with the operating conditions (→ “Technical data / Scope of supply”, page 23) and the operating manual and noting and following the reference documents.
- ▶ When using the local regulations note: laws, standards, guidelines, directives.

All other uses of the unit are not as intended.

### 2.2 Personnel qualifications

The operating manuals supplied with the product are intended for all users of the product.

The operation of the product via the heating and heat pump control and work on the product which is intended for end customers / operators is suitable for all age groups of persons who are able to understand the activities and the resulting consequences and can carry out the necessary activities.

Children and adults who are not experienced in handling the product and do not understand the necessary activities and the resulting consequences must be instructed and, if necessary, supervised by persons experienced in handling the product and who are responsible for safety.

Children must not play with the product.

The product may only be opened by qualified personnel.

All procedural instructions in this operating manual are solely directed at qualified specialist personnel.

Only qualified, skilled personnel is able to carry out the work on the unit safely and correctly. Interference by unqualified personnel can cause life-threatening injuries and damage to property.

- ▶ Ensure that the personnel is familiar with the local regulations, especially those on safe and hazard-aware working.
- ▶ Ensure that the personnel are qualified to handle flammable (primary) refrigerant.
- Work on the refrigerating circuit may only be carried out by qualified personnel with appropriate qualifications for refrigeration system installation.
- Work on the electrics and electronics may only be carried out by electrical technicians.
- Any other work on the system may only be carried out by qualified personnel (heating installer, plumbing installer).

During the warranty and guarantee period, service work and repairs may only be carried out by personnel authorised by the manufacturer.

### 2.3 Personal protective equipment

During transport and work on the unit, there is a risk of cuts due to the sharp edges of the unit.

- ▶ Wear cut-resistant protective gloves.

During transport and work on the unit, there is a risk of foot injuries.

- ▶ Wear safety shoes.

When working on liquid-conveying lines, there is a risk of injury to the eyes due to leakage of liquids.

- ▶ Wear safety goggles.

### 2.4 Residual risks

#### Electric shock

Components in the unit are live with life-threatening voltage. Before working on the unit:

- ▶ Disconnect unit from power supply.
- ▶ Protect unit against being switched back on again.
- ▶ Residual voltage at the inverter. Wait 5 minutes before opening the device.



Existing earthing connections within housings or on mounting plates must not be altered. If this should nevertheless be necessary in the course of repair or assembly work:

- ▶ Restore earthing connections to their original condition after completion of the work.

### Injuries caused by moving parts

- ▶ Only switch on the unit once outer panels and the flexible air duct system ADH have been fitted.

### Injuries caused by high temperatures

- ▶ Before working on the unit, let it cool down.

### Safety instructions and warning symbols

- ▶ Observe the safety instructions and warning symbols on the packaging and on and in the unit.

### Injuries and environmental damage due to refrigerant



#### **WARNING**

**The unit contains flammable (primary) refrigerant that is hazardous to health and the environment. If (primary) refrigerant leaks from the unit, there is a risk of an explosion.**

Proceed as follows if refrigerant leaks from the unit due to a leak:

1. Switch off unit.
2. Ensure that all unauthorised persons leave the danger area immediately.
3. Remove possible ignition sources from the danger area and keep them away from the danger area.
4. Block access to the danger area for unauthorised persons.
5. Notify authorised after sales service.

If damage is visible on the outside of the unit, proceed as follows:

1. Switch off unit.
2. Notify authorised after sales service.

## 2.5 Disposal

### Environmentally hazardous substances

Improper disposal of environmentally hazardous substances (e.g. refrigerant, compressor oil) damages the environment:

- ▶ Collect substances safely.
- ▶ Dispose of the substances in an environmentally-friendly manner according to the local regulations.

## 2.6 Avoid damage to property

The ambient air at the heat pump installation site, as well as the air drawn in as a heat source, must not contain any corrosive constituents!

Constituents such as

- Ammonia
- Sulphur
- Chlorine
- Salt
- Sewer gasses, flue gasses

can cause damage to the heat pump, which could lead to the complete failure / destruction of the heat pump!

### Cooling

If the heating surfaces are used for heating and cooling, the control valves must be suitable for heating and cooling.

By cooling with low flow temperatures, condensate can be expected to form on the heat distribution system as the temperature falls below the dew point. If the heat distribution system is not designed for these operating conditions, it must be protected by appropriate safety devices, e.g. dew point monitor (purchasable accessory).

### Decommissioning / emptying heating

If the system / heat pump is decommissioned or emptied, after it has been filled already, it is necessary to ensure that the condenser and any heat exchangers present have been completely emptied in the event of frost. Residual water in heat exchangers and condensers can result in damage to components.

- ▶ Empty system and condenser completely, open vent valves.
- ▶ Blast out with compressed air if necessary.



## Improper action

Requirements for minimum scale and corrosion damage in hot water heating systems:

- Proper planning, design and commissioning
- Closed system with regard to corrosion
- Integration of an adequately dimensioned pressure maintaining device
- Use of demineralised heating water (VE water) or water corresponding to the VDI 2035 norm
- Regular servicing and maintenance

If a system is not planned, designed, started up and operated in accordance with the given requirements, there is a risk that the following damage and faults will occur:

- Malfunctions and the failure of components, e.g. pumps, valves
  - Internal and external leaks, e.g. from heat exchangers
  - Cross-section reduction and blockages in components, e.g. heat exchanger, pipes, pumps
  - Material fatigue
  - Gas bubbles and gas cushion formation (cavitation)
  - Negative effect on heat transfer, e.g. formation of coatings, deposits, and associated noises, e.g. boiling noises, flow noises
- Note and follow the information in this operating manual for all work on and with the unit.

## Unsuitable quality of the fill and make-up water in the heating circuit

The efficiency of the system and the life of the heat generator and the heating components depend decisively on the quality of the heating water.

If the system is filled with untreated drinking water, calcium and magnesium precipitate as mineral scale. Limescale deposits form on the heat transfer surfaces of the heating. The efficiency drops and energy costs rise. In extreme cases the heat exchangers are damaged.

- Fill the system with deionised heating water (VE water) or with water corresponding to the VDI 2035 norm only (low-salt operation of the system).

## 3 Description

### 3.1 Delivery condition

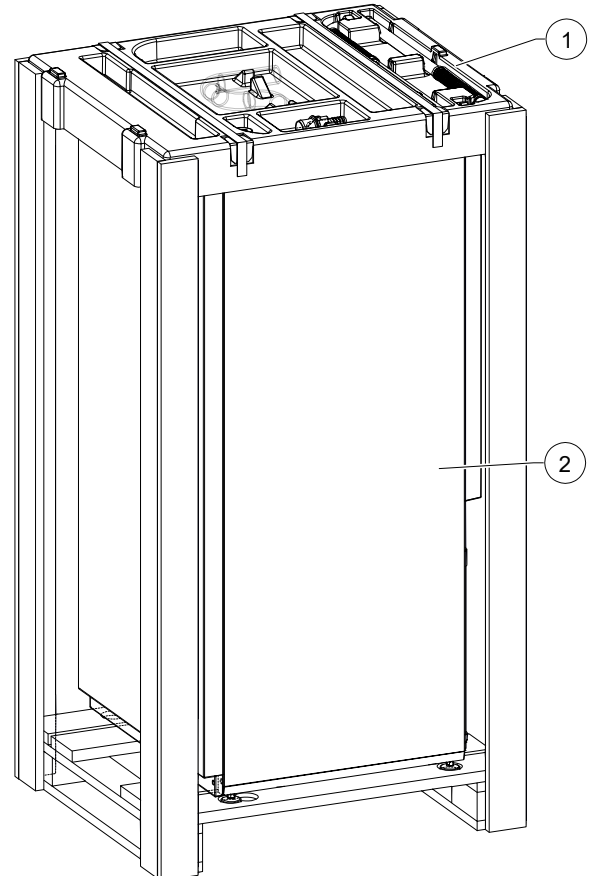

- 1 Accompanying parts package  
2 Heat pump



## 3.2 Layout



### NOTE

This section essentially names the components relevant for fulfilling the tasks described in this operating manual.

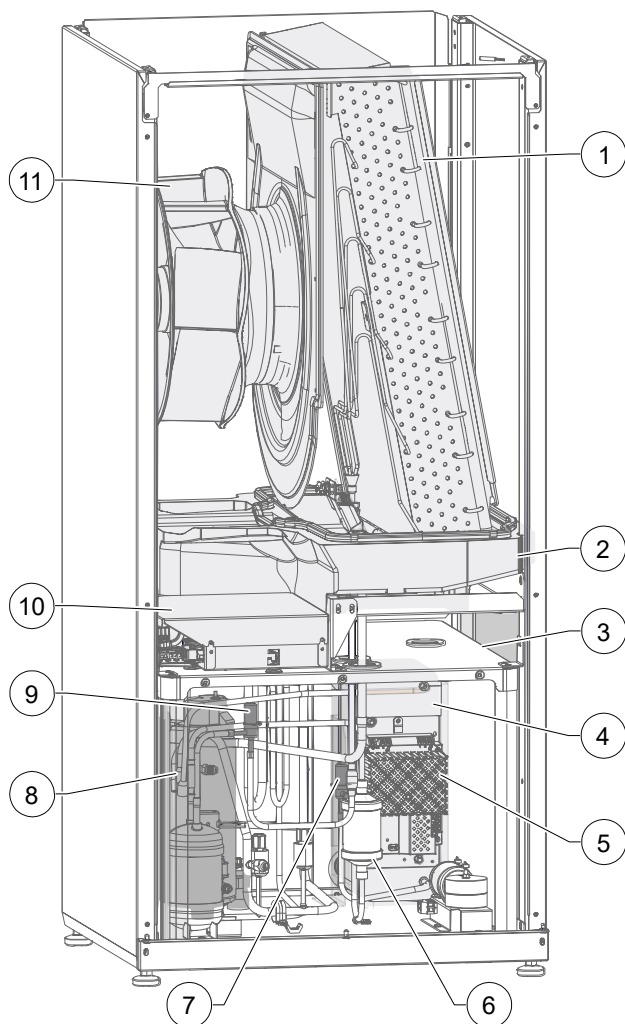

- 1 Evaporator
- 2 Condensate pan
- 3 Module box
- 4 Condenser
- 5 Inverter unit
- 6 Filter dryer
- 7 Expansion valve (cooling, defrost)
- 8 Compressor (in the insulated housing)
- 9 Expansion valve (heating)
- 10 Electrical switch box
- 11 Fan

## Nameplates

One nameplate is attached to the outside of the unit on a side facade at the factory, a second one is attached to the module box inside of the unit.

Another nameplate is included in the scope of delivery.

- ▶ Glue this nameplate into the logbook for heat pumps.

The nameplates contain the following information at the very top:

- Model, item number
- Serial number

The nameplates also contain an overview of the most important technical data.

## 3.3 Accessories

### Functionally necessary accessories

Only use genuine accessories made by the manufacturer of the device.

- Flexible air duct system ADH
  - Wall-mounted controller WR 4
- or
- Hydraulic module HV 4
- or
- Hydraulic station HSV 4

### Additional accessories

The following accessories are available for the unit through the manufacturer's local partner:

- Electrical connection kit EVS or EVS 8
- Air / magnetic sludge separator
- Domestic hot water tank
- Buffer tank
- 3-way switching valve with valve motor
- Overflow valve
- Room thermostat for switching the cooling function
- Dew point monitor for protecting a system with cooling function at low flow temperatures
- Room control panel for controlling the main functions at the living quarters
- Condensate Overflow Protection Set COPS



### 3.4 Function

Liquid refrigerant is evaporated (evaporator), the energy for this process is environmental heat and comes from the outside air. The gaseous refrigerant is compressed (compressor), this causes the pressure to rise and therefore the temperature too. The gaseous refrigerant at a high temperature is liquefied (condenser).

The high temperature is hereby discharged to the heating water and is used in the heating circuit. The liquid refrigerant at a high pressure and high temperature is depressurised (expansion valve). The pressure and temperature drop and the process begins again.

The heated heating water can be used for the domestic hot water charging or for the building heating. The temperatures required and use are controlled by the heat pump controller. Reheating, drying out screed or increasing the domestic hot water temperature can be carried out using an electric heating element, which is activated by the heat pump controller as and when necessary.

The vibration decoupling for the hydraulics prevent structure-borne sound and vibrations from being transferred into the fixed pipes and therefore into the building.

#### Cooling

Cooling is integrated in the units. The following options are possible for units with cooling function (→ operating manual of the heating and heat pump controller):

- Active cooling  
Cooling down to a minimum flow temperature of 18°C possible in combination with hydraulic module HV 4 or hydraulic station HSV 4. Possible to 7°C in conjunction with wall-mounted controller WR 4.
- Cooling below 18°C is only possible in the case of hydraulic integration with separation buffer tank
- Control of the cooling function via the heating and heat pump controller
- Changeover between heating and cooling operation

## 4 Operation and care



### NOTE

The unit is operated via the control panel of the heating and heat pump controller (→ operating manual of the heating and heat pump controller).

### 4.1 Energy-conscious and environmentally-aware operation

The generally accepted requirements for an energy-conscious and environmentally-aware operation of a heating system also apply when using a heat pump. The most important measures include:

- No unnecessarily high flow temperature
- No unnecessarily high domestic hot water temperature
- Do not open windows with gap / tilt open (continuous ventilation), but instead open wide for a short time (shock ventilation).
- Make sure that the controller settings are correct.

### 4.2 Care

Wipe down the outside of the unit only using a damp cloth or cloth with mild cleaning agent (washing-up liquid, neutral cleaning agent). Do not use any harsh, abrasive, acid or chlorine-based cleaning agents.





## 5 Delivery, storage, transport and installation

### IMPORTANT

Damage to the housing and the unit components due to heavy objects.

- ▶ Do not place any objects on the unit.

### 5.1 Scope of supply

- ▶ Check delivery immediately after receipt for externally visible damage and completeness.
- ▶ Notify supplier of any defects immediately.

The accompanying parts package contains

- Hydraulic connection pipe with integrated vibration decoupling and seal (2x)
- Condensate drain syphon (1x)
- Pipe connector (1x)
- Spring clamps for condensation hose (2x)
- Insulation for condensate drain syphon (1x)
- Documents (manuals, ERP data and label)
- Nameplate

### 5.2 Storage



#### WARNING

The unit may only be stored in rooms that do not contain ignition sources. Do not drill or torch!

- ▶ Do not unpack the unit until directly before installation if possible.
- ▶ Store unit protected against
  - Moisture/damp
  - Frost
  - Dust and dirt

## 5.3 Transport and unpacking

### Notes on safe transport

The unit is heavy (→ “Technical data / Scope of supply”, page 23). There is a risk of injuries or damage to property if the unit falls or overturns.

The hydraulic connections are not designed for mechanical loads.

- ▶ Do not lift or transport the unit by the hydraulic connections.

Transport the unit preferably with a pallet truck, alternatively with a handcart or by carrying

- ▶ Do not tilt the unit by more than 45°.

### 5.3.1 Transport with a pallet truck

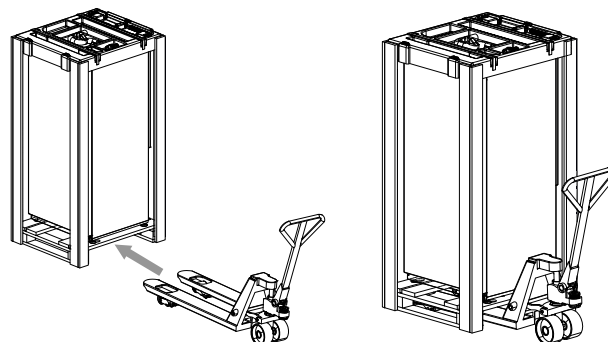

### 5.3.2 Unpacking

1. Remove plastic films. Ensure that you do not damage the unit.
2. Lift off EPS packaging with the accompanying parts package from the unit and put it in a safe place.
3. Dispose of the transport and packaging material in an environmentally friendly way and in accordance with local regulations.

### 5.3.3 Transport with a handcart

1. Remove the front panel and put it down in a safe place.

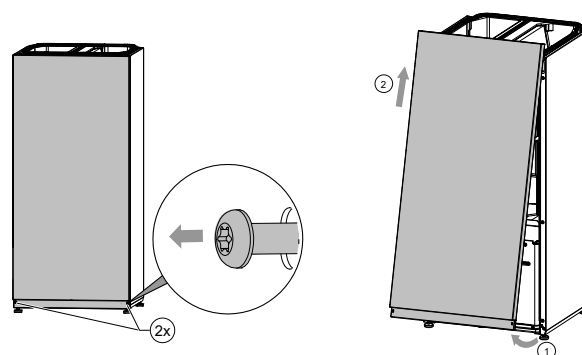



- Remove the side panels and put it down in a safe place.

Example of right side panel:

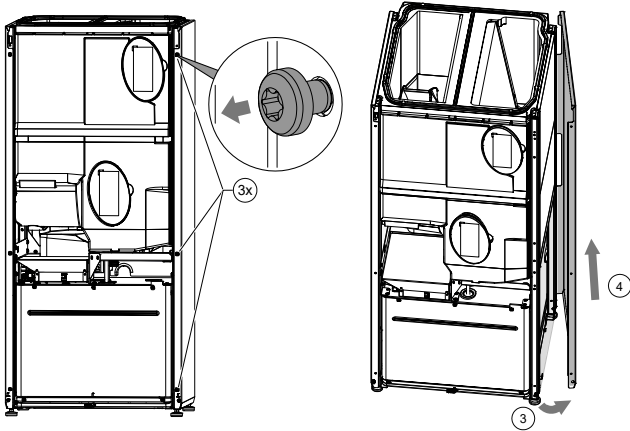

- Proceed in reverse order to reattach the panels.

- Lift the unit from the front onto a handcart and secure it there before transporting it to the installation site.

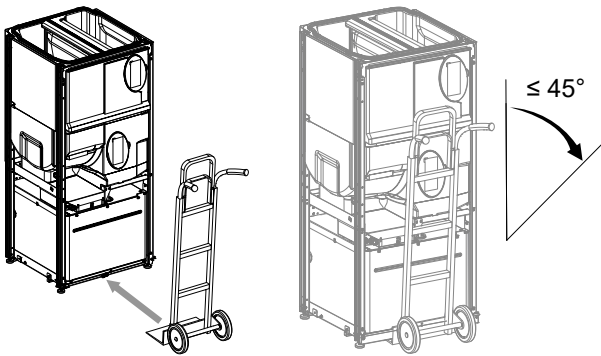

### 5.3.4 Carrying the unit

- Remove the panels of the unit.
- “5.3.3 Transport with a handcart”, page 9
- Carry the unit to the installation site with 2 persons using the 4 lashing straps.

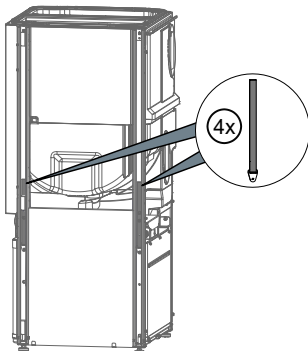

## 5.4 Installation



### CAUTION

In the air outlet area the air temperature is approx. 5 K below the ambient temperature. Under certain climatic conditions, an ice layer can therefore form in the air outlet area. Install the heat pump such that the air blower does not discharge into footpath areas.

### Installation room and space requirements



### NOTE

Note and follow the local regulations and standards regarding the installation room and space requirements. The table shows the regulations according to EN 378-1 relevant in Germany.

Refrigerant	Limit value [kg/m <sup>3</sup> ]
R 134a	0.25
R 404A	0.52
R 407C	0.31
R 410A	0.44
R 448A	0.39
R 454B	0.358

→ “Technical data / Scope of supply”, page 23

$$\text{Minimum room volume} = \frac{\text{Refrigerant capacity [kg]}}{\text{Limit value [kg/m}^3\text{]}}$$



### NOTE

If several heat pumps of the same type are installed, only one heat pump need to be taken into account. If several heat pumps of different types are installed, only the heat pump with the largest refrigerant volume needs to be taken into account.



- ✓ Minimum volume corresponds to the requirements for the refrigerant used.
- ✓ Installation inside the building only.
- ✓ Installation room is dry and frost-free.
- ✓ Requirements for flexible air duct system ADH are met.
- Installation manual of the flexible air duct system ADH
- ✓ Clearance dimensions are met.
- "Installation plans", from page 27
- ✓ The floor is suitable for installation of the unit:
  - level and horizontal
  - Load-bearing capacity for the unit's weight



#### NOTE

The noise emissions of the heat pumps must be taken into account in the respective installation plans for air/water heat pumps. The respective regional regulations must be observed.



#### NOTE

The unit should not be installed immediately next to, below or above noise-sensitive rooms (e.g. bedrooms, children's rooms, etc.). If the unit is nonetheless installed in the immediate proximity of noise-sensitive rooms, we recommend that additional constructional measures be taken to reduce noise. No air intake or outlet openings should be located in the proximity of the windows of noise-sensitive rooms.

- ▶ If the condensate overflow protection set COPS (accessory) is used, place the unit in the condensate overflow protection pan.
- Installation instruction: Condensate overflow protection set COPS

## Aligning the unit

1. Align the unit horizontally and stably at the installation site using the height-adjustable feet (①) and a size 13 spanner.  
Adjustment range: 20 mm.

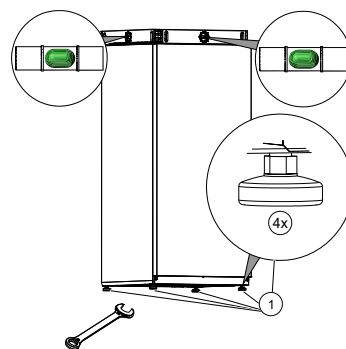

## 5.5 Installation of air ducting

- Operating manual of the flexible air duct system ADH

## 6 Installing the hydraulic connections

### IMPORTANT

Avoid open heating systems and / or heating systems that are not oxygen diffusion-tight. If this is not possible, a system separation must be installed.

Depending on the dimensioning of the heat exchanger and the additionally required circulation pump, the system separation worsens the energy efficiency of the system.

### IMPORTANT

Dirt and deposits in the (existing) hydraulic system can cause damage to the heat pump.

- ▶ Ensure that a air / magnetic sludge separator is installed in the heating circuit.
- ▶ Ensure that a dirt filter with a mesh size of 0.7 mm is installed as close as possible to the heating water inlet (return).
- ▶ Rinse the hydraulic system thoroughly prior to establishing the hydraulic connection of the heat pump.

### IMPORTANT

Damage to the copper pipes due to unacceptable loading!

- ▶ Secure all connections against twisting.
- ✓ Cross-sections and lengths of the pipes for the heating circuit are adequately dimensioned.



- ✓ The free pressing of the circulation pumps in the heating circuit at least results in the throughput required for the device type (→ “Technical data / Scope of supply”, page 23).
  - ✓ The hydraulic system must be equipped with a buffer tank, the required volume of which depends on your unit model.
  - “Technical data / Scope of supply”, page 23
  - ✓ The pipes for the heating are fixed to the wall or ceiling via a fixed point.
1. Attach the hydraulic connection pipes (①) to the connections (②) on the back of the unit. Use seals from the accompanying parts package.

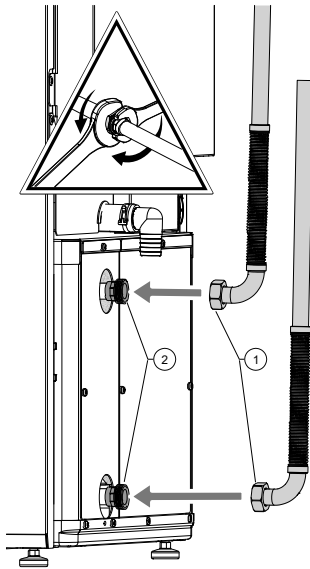

2. Depending on the connection situation heating circuit ↔ heat pump form the vibration decouplings into a 90° elbow bend to the right or to the left. When laying to the right: Route the vibration decoupling for the heating water supply (④) above the condensate outlet (⑤). Example of connection to the right:

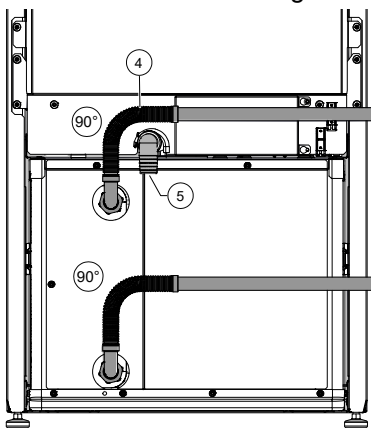

### IMPORTANT

Straight or stretched laying of the vibration decouplings is not permitted.

3. Connect the hydraulic connection pipes to the corresponding fixed piping of the heating circuit.

### i NOTE

Hydraulic connection pipes can be shortened if necessary.

4. Insert a vent at the highest point of the heating circuit.
5. Ensure that the working overpressures (→ “Technical data / Scope of supply”, page 23) are not exceeded.

### Pressure relief for hydraulic line

- ▶ If there is a shut-off valve between the heat generator and the heat sink, fit a pressure relief valve.

### Condensate connection

The outlet for the heating water safety valve and the condensate from the air must be drained off in accordance with the respective applicable standards and regulations. Discharging the condensate and the safety valve outlet into the sewers is only permitted via a funnel waste trap, which must be accessible at all times.

### i NOTE

The condensate connection can be attached to the right or left.

1. Use components from the accompanying parts package.

Example: condensate connection to the right

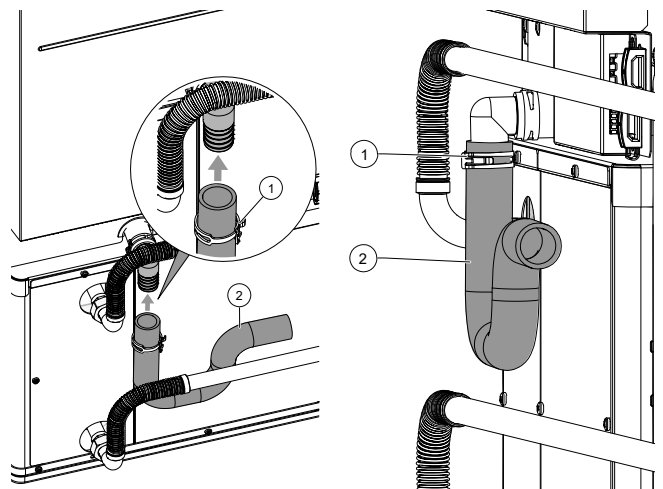

- 1 Spring clamp
- 2 Syphon

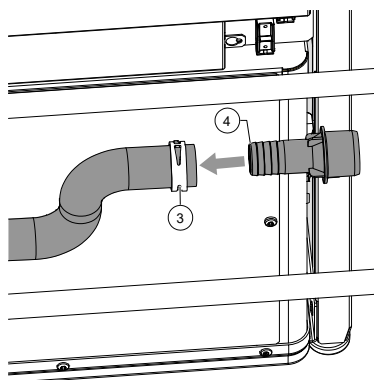

- 3 Spring clamp
- 4 Pipe connector

2. Attach a sewage pipe (on site) (5) to the pipe connection (4) and lay it on a gradient to the sewers.

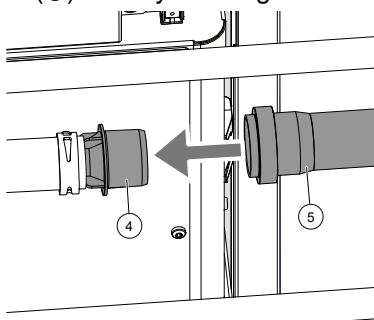

3. Apply insulation (6) to the syphon and fix with cable ties (7).

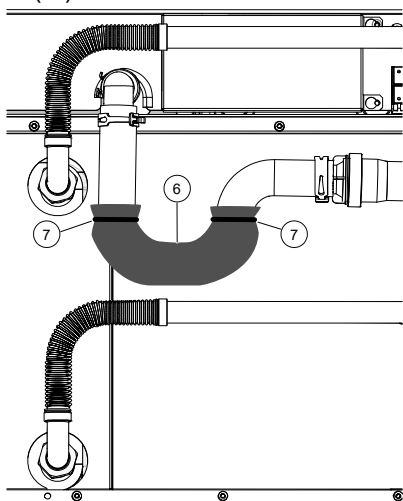

## 7 Electrical installation

### 7.1 Connect the electrical cables

#### IMPORTANT

Irreparable damage to the compressor due to wrong rotary field (only applies to units with 400V connection).

- ▶ Ensure that there is a clockwise rotary field for the compressor load infeed.

#### Basic information on the electrical connection

- The specifications of the local energy supply company may apply to electrical connections
- Fit the power supply for the heat pump with an all-pole miniature circuit-breaker with at least 3 mm contact spacing (per IEC 60947-2)
- Note the level of the tripping current (→ “Technical data / Scope of supply”, page 23)
- Comply with the electromagnetic compatibility regulations (EMC regulations)
- Lay unshielded power supply cables and shielded cables (bus cable) sufficiently far apart (> 100 mm).

The electrical connection of the heat pump with the hydraulic unit or the wall-mounted controller is established using the EVS8 or EVS accessory.

- EVS 8: plugs and sockets for load and bus cables with 8m cable each.  
A maximum of 3 EVS 8 connections are possible.  
→ EVS 8 installation instructions
- EVS: plugs and sockets for load and bus cables.  
Bus cable on site, maximum cable length of 30 m.  
The bus cable must be a shielded cable of at least  $4 \times 0.5 \text{ mm}^2$ .  
As load cable:  
A  $3 \times 2.5 \text{ mm}^2$  cable with protective conductor, Diameter of the sheath of the electric cable cable 9 – 13 mm<sup>2</sup>



- ▶ Mount the sockets (Ⓑ) towards the heat pump, the plugs (Ⓢ) towards the hydraulic unit or the wall-mounted controller.

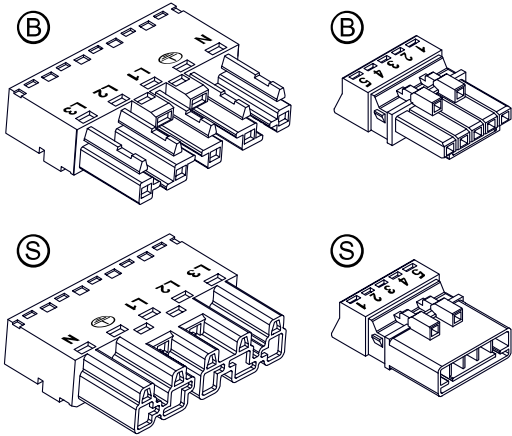

### Mounting EVS 8 / EVS (accessories)

1. Connect the compressor load cable to the five-pin load cable socket.
  - 1.1. Break a lock of one of the cable bushings (①) carefully out of the pre-engaged strain relief housing (②) and push the strain relief housing approx. 50 cm over the load cable (③).

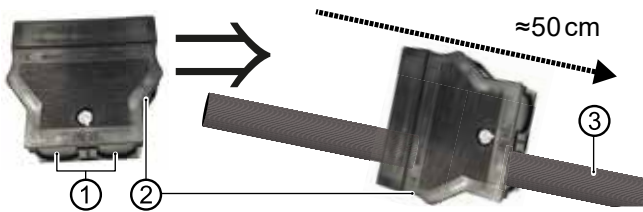

- 1.2. Strip the load cable 55 mm.



- 1.3. Shorten the live wires so that the PE conductor has a lead of 8 mm.



- 1.4. Strip each wire 9 mm.



- 1.5. Insert the stripped wires into the pins (④).

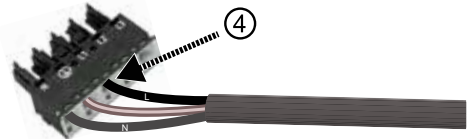

- ▶ If the load cable has single wires, insert each of them as far as they will go:

Insert the N and PE conductor in the pins labelled accordingly and insert the L conductor in the L1 pin.

- ▶ If the load cable has fine wire strands:
  - Twist the strands of each wire.

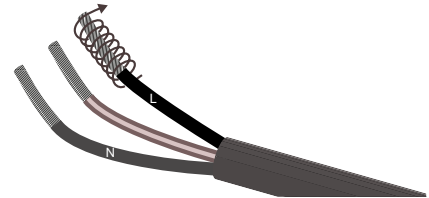

- 1.5.1. Insert an operating tool or screwdriver (2.5 mm blade width) in the connection lock of the neutral pin to unlock the connection lock.

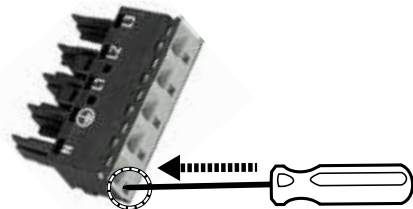

- 1.5.2. Insert the twisted wire of the neutral conductor as far as it will go into the neutral pin.

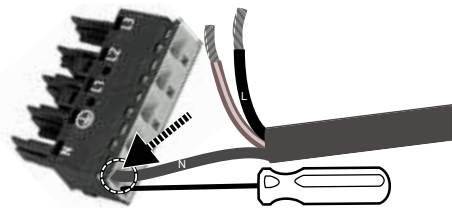

- 1.5.3. Pull the operating tool or screwdriver out of the connection lock to lock the connection.

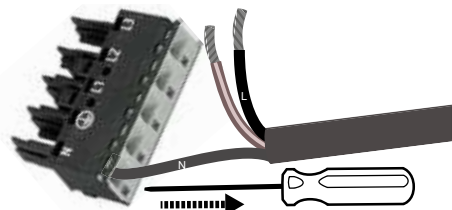



1.5.4. Insert the PE conductor in the pin labelled accordingly and insert the L conductor in the L1 pin:

**IMPORTANT**

Check each inserted wire for tight fitting in its pin.

1.6. Push the strain relief housing (2) onto the wired socket (4).



1.7. Align them correctly to each other: The top side of the socket and the top side of the strain relief housing are both marked with "TOP".

1.8. Push the socket as far as it will go into the strain relief housing.



1.9. Lock the top part of the strain relief housing firmly onto the bottom part.

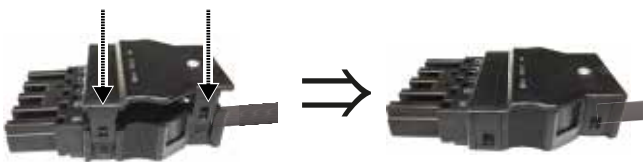

1.10. Screw the strain relief screw tight.

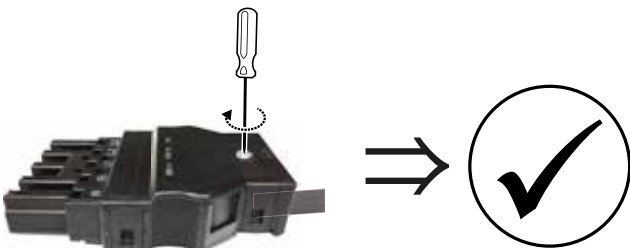

2. Connect the bus cable (communication) to the bus cable socket.



2.1. Insert the contact spring (5) into pin 3 (6) up to the limit stop  
The lugs on the broad end of the contact spring must point upwards (in the direction of the numbers on the socket).

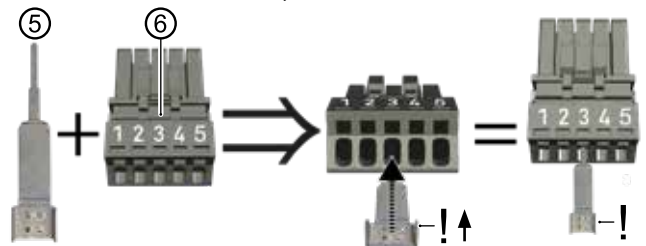

**NOTE**

If the contact spring is in the way when subsequently inserting the wires of the bus cable, it can be disconnected and re-connected after inserting the wires.

2.2. Strip the bus cable 30 mm.

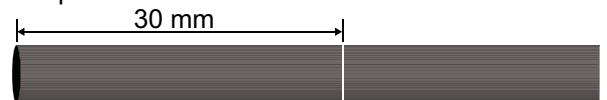

2.3. Push the shielding braid back 10 mm over the sheath.

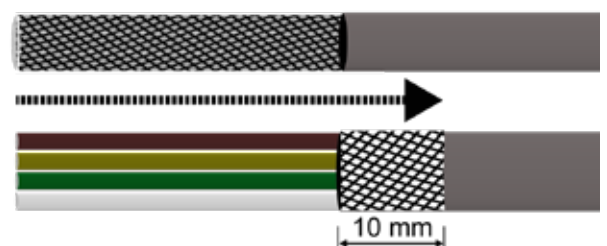

2.4. Pull back the shielding foil up to the shielding braid and cut off.

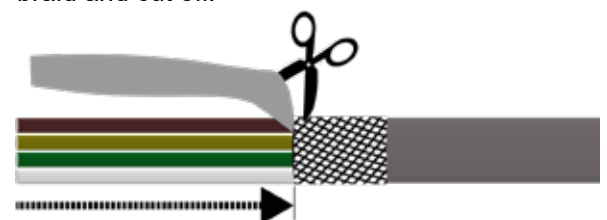



2.5. Strip each wire 9 mm.



2.6. Twist the strands of each wire.

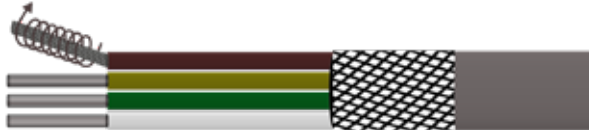

2.7. Insert the stripped wires into the pins.

2.7.1. Insert an operating tool or screwdriver (blade 2.5x0.4mm) in the connection lock on pin 5 to unlock connection lock.

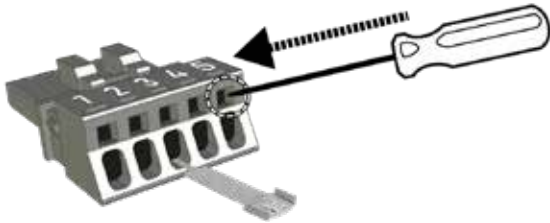

2.7.2. Place the cable with shielding braid onto the contact spring from above and insert the white wire into pin 5 up to the limit stop.

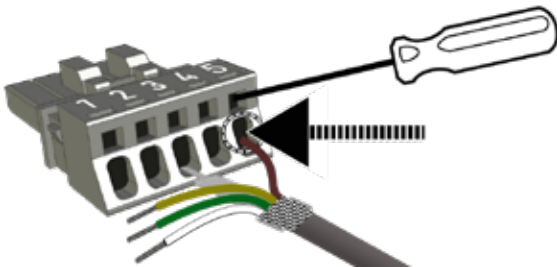

2.7.3. Pull the operating tool or screwdriver out of the connection lock and thereby lock the connection.

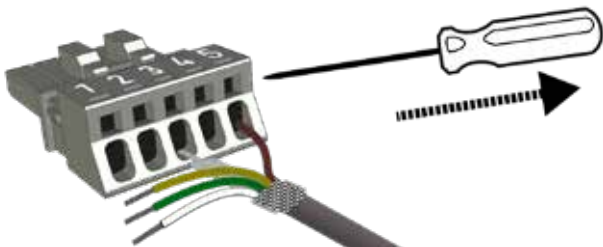

2.7.4. Insert the three other wires in the same way into the corresponding pins.

Assignments of the pins

white wire of the bus cable	pin 1
green wire of the bus cable	pin 2
Shielding braid on contact spring	pin 3
yellow wire of the bus cable	pin 4
brown wire of the bus cable	pin 5

### IMPORTANT

Check each inserted wire for tight fitting in its pin.

2.8. Place the shielding braid on the contact spring and, if necessary, shorten it so that it does not go beyond the contact spring.

2.9. Assemble the strain relief housing.

2.9.1. Snap the wired socket into the lower part (7) of the strain relief housing.

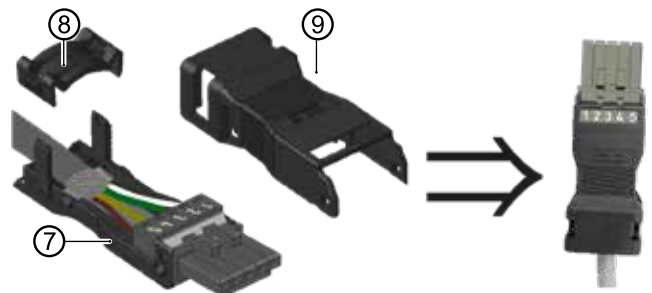

2.9.2. Fit the strain relief (8) and clip into place until the bus cable is clamped firmly.

### IMPORTANT

The shielding braid must have a direct and firm contact with the contact spring.

2.9.3. Snap the upper part of the housing (9) fully onto the lower part.





3. Connect the wired load and bus cable sockets to the unit.
- 3.1. Remove the cover (10) for the plug-in connections on the back of the unit.

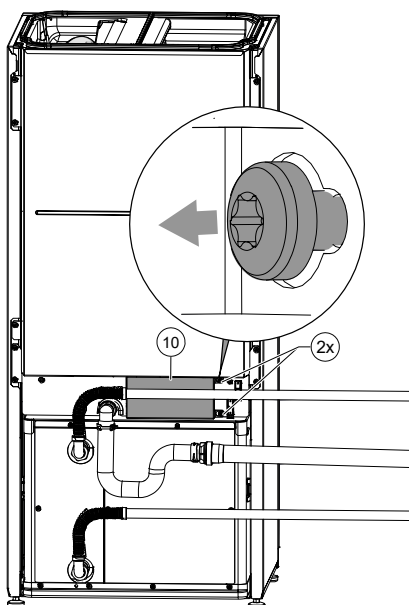

- 3.2. Open the strain reliefs (11) of the unit.

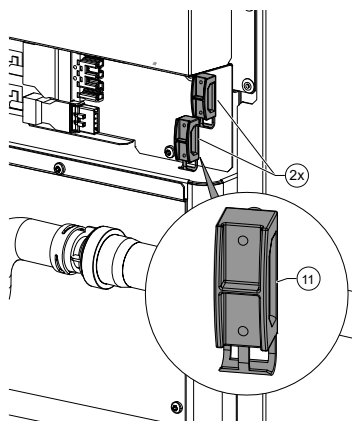

- 3.3. Insert the load cable socket (12) and bus cable socket (13) up to the limit stop into the corresponding plugs.

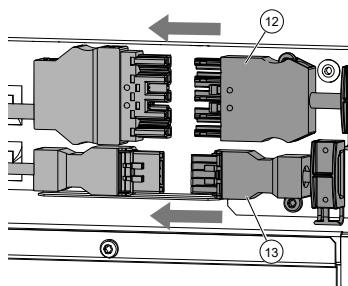

- 3.4. Route both cables through the strain reliefs in the unit, close the strain reliefs and tighten the strain reliefs.

- 3.5. Mount the cover of the plug-in connections.
4. Guide the load and bus cable from the heat pump to the electrical switch box of the hydraulic unit or to the wall-mounted controller.
  - Operating manual of the hydraulic unit or
  - Operating manual of the wall-mounted controller
5. Mount the plugs on the load cable and the bus cable in the same way as the sockets.

### IMPORTANT

The wire assignment of the bus cable plug must match the wire assignment of the bus cable socket.

- "Assignments of the pins", page 16
- 6. Insert the load cable plug and bus cable plug up to the limit stop into the corresponding sockets on the underside of the electrical switch box of the hydraulic unit or in the wall-mounted controller.
  - Operating manual of the hydraulic unit or
  - Operating manual of the wall-mounted controller



## 8 Flushing, filling and venting

### 8.1 Heating water quality



#### NOTE

For detailed information refer, among other things, to the VDI Guidelines 2035 “Vermeidung von Schäden in Warmwasserheizanlagen” (preventing damage in hot water heating systems).

1. Ensure that the pH-value of the heating water is between 8.2 – 10, for aluminium materials between 8.2 – 9.  
Ideally, the pH value should already be in the required range after filling. After 6 weeks at the latest, it must have adjusted to the required range.
2. Ensure that the electrical conductivity is  $< 100 \mu\text{S}/\text{cm}$ .



#### NOTE

If the required water quality is not achieved, consult a company specialising in the treatment of heating water.

3. Fill the system with deionised heating water (VE water) or with water corresponding to the VDI 2035 norm only (low-salt operation of the system).  
Advantages of low-salt operation:
  - Low corrosion-promoting properties
  - No formation of mineral scale
  - Ideal for closed heating circuits
4. Keep a system log for hot water heating systems in which relevant planning data and the water quality are entered (VDI 2035).

### 8.2 Flush, fill and vent the heating circuit

- ✓ Outlet pipe of the safety valve is connected.
- Ensure that the set pressure of the safety valve is not exceeded.

#### IMPORTANT

Flush the heating circuit only in its flow direction.



#### NOTE

The venting program on the controller can also be used to support the flushing and venting process. It is possible to control individual recirculating pumps and even the switching valve through the venting program. The valve motor then does not have to be removed.

1. Vent system at the respective highest point.
2. Pull off the U-clip (①) on the back of the valve motor (②) on the switching valve (③, integrated in hydraulic station HSV 4, accessories for module for hydraulics HV 4 or wall-mounted controller) upwards.

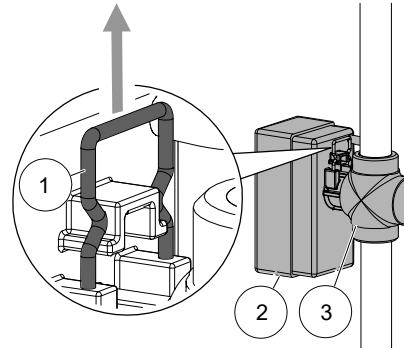

3. Carefully pull the valve motor (②) forward off the 3-way switching valve (③).

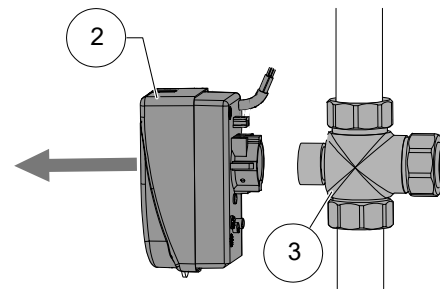

4. Turn the spindle of the 3-way switching valve so that the rounded side of the spindle points in the direction of marking A of the connections of the 3-way switching valve.

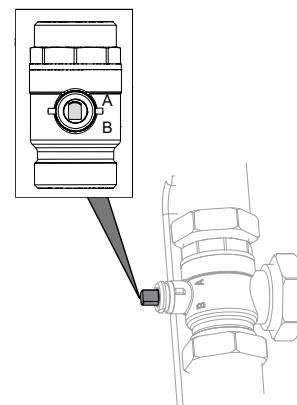

5. Flush the domestic hot water charging circuit for approx. 1 minute.
6. Turn the spindle so that the rounded side of the spindle points in the direction of marking B of the connections of the 3-way switching valve.



7. Flush heating circuit thoroughly, until no more air is discharged.
8. Position the valve motor (②) on the 3-way switching valve (③).

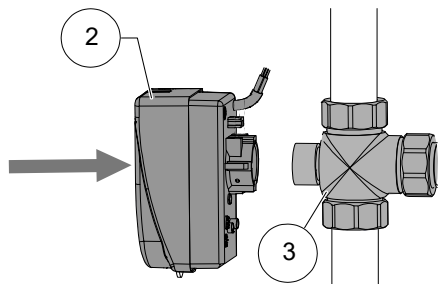

9. Insert the U-clip (①) on the back of the valve motor (②).

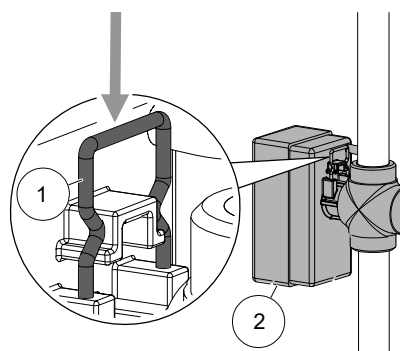

10. Ensure that the U-clip has latched into position correctly:
    - ✓ Valve motor sits securely on the 3-way switching valve.
    - ✓ Both prongs of the U-clip sit on the lug.
    - ✓ The tips of the U-clip are not visible more than approx. 2 mm.
  11. Swap the hoses at the filling and draining stop cocks and flush the condenser of the heat pump via the return.
  12. In addition, open the vent valve on the condenser of the heat pump. Vent the condenser and then close the vent valve again when fully vented.
- Operating manual of the switching valve

## 9 Insulate hydraulic connections

Insulate hydraulic lines in accordance with local regulations.

1. Open shut-off devices.
2. Perform a pressure test and check for leaks.
3. Insulate external piping on site.
4. Insulate all connections, fittings and pipes.
5. If the device is used for cooling below 18°C (only possible in combination with the wall-mounted controller), the insulation must be vapour diffusion-tight.

## 10 Overflow valve

(integrated with Hydraulic station HSV4, accessory with hydraulic module HV4 or wall-mounted controller)



### NOTE

- The activities in this section are only necessary for the integration of storage tanks in series
  - Complete the work steps quickly, otherwise the maximum return temperature may be exceeded and the heat pump switches to high-pressure fault
  - Turn the adjusting knob at the overflow valve to the right to increase the temperature difference (the temperature drop), turn it to the left to reduce it
- ✓ System is running in heating mode (ideally in cold condition).

The IBN assistant already provides the option, in the event of the integration of the storage tank in series to adjust the overflow valve according to the hydraulic system.

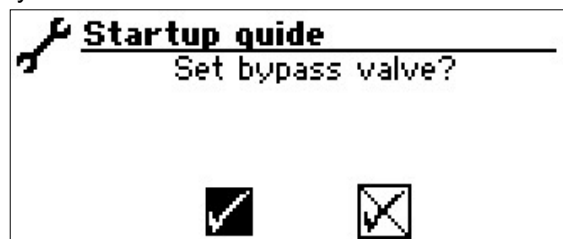

Confirm the IBN assistant or:

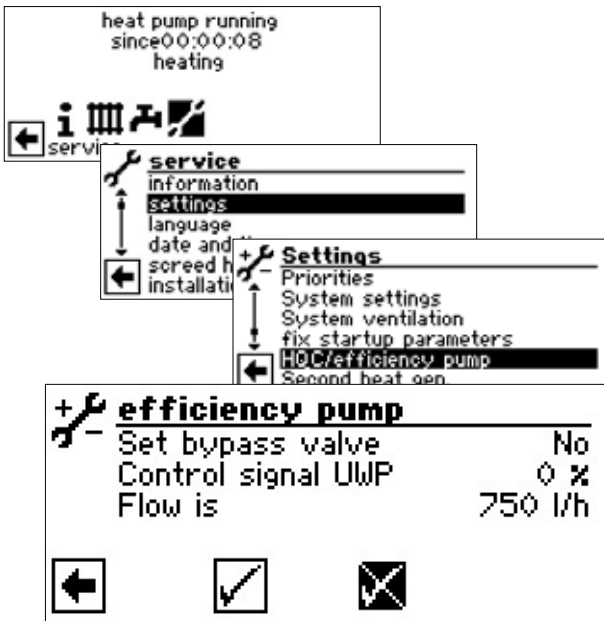

The “Set bypass valve” menu item is set by default to “No”. The overflow valve adjustment function is deactivated.

- The UWP control signal is the indication of the currently required pump capacity in %
  - If the flow rate is the current flow rate (measuring accuracy +/- 200 l/h)
1. Fully open the overflow valve (①) with the rotary button (②), close the heating circuits.

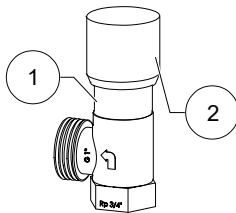

2. If the “Set bypass valve” menu item is set from “No” to “Yes”, the circulation pump is activated with 100% – and the pump starts up.
3. If the control signal UWP reaches 100%, close the overflow valve to the extent that the maximum flow rate (→ “Technical data / Scope of supply”, page 23) can be ensured.
4. If you exit the “Set bypass valve” menu or at the latest after one hour, the circulation pump switches back to standard regulation
5. Open valves to heating circuit.

## 11 Commissioning

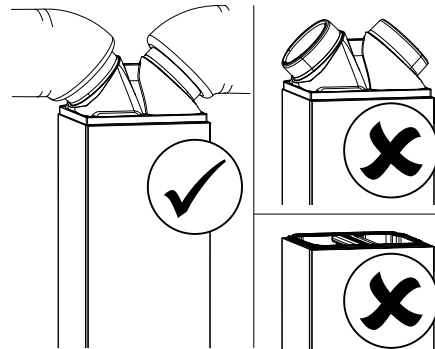

### CAUTION

Start up the unit only with fully installed components of the flexible air duct system ADH and closed facing panels.

- ✓ Relevant planning & design data of the system is documented in full.
  - ✓ The relevant energy supply company has been notified of operation of the heat pump system.
  - ✓ The system is air-free.
  - ✓ Installation check using the general checklist has been completed successfully.
  - ✓ Right-hand (clockwise) rotating load supply field is available at the compressor (only applies to units with 400V connection).
  - ✓ The system is installed and mounted according to this operating manual
  - ✓ The electrical installation has been carried out properly according to this operating manual and the local regulations
  - ✓ The power supply for the heat pump is equipped with an all-pole circuit-breaker with at least 3 mm contact spacing (IEC 60947-2)
  - ✓ The tripping current is complied with
  - ✓ The heating circuit has been flushed and vented
  - ✓ All shut-off devices of the heating circuit are open
  - ✓ The pipe systems and components of the system are tight
1. Carefully fill in and sign the notice of completion for the heat pump systems.
  2. In Germany: Send notice of completion for heat pump systems and general checklist to the manufacturer’s factory customer service department. In other countries: Send notice of completion for heat pump systems and general checklist to the manufacturer’s local partner.



3. Arrange for the heat pump system to be commissioned by the manufacturer's authorised after sales service for a fee.

→ "12.2 Maintenance after commissioning", page 21

## 12 Maintenance



### NOTE

We recommend that you conclude a maintenance agreement with an accredited heating company.

### 12.1 Basic principles

The cooling circuit of the heat pump requires no regular maintenance.

Local regulations require, among other things, leak checks beforehand and/or for a logbook to be kept for certain heat pumps.

- ▶ Ensure compliance with local regulations with regard to the specific heat pump system.

### 12.2 Maintenance after commissioning

Immediately after commissioning, check all installed dirt traps for dirt and clean them if necessary.

- ▶ Switch off the system while the check and cleaning is being carried out.

Next checking and cleaning at the latest 2 weeks after commissioning.

### 12.3 Maintenance as required

- Checking and cleaning the components of the heating circuit, e.g. valves, expansion vessels, recirculating pumps, filters, dirt traps
- Test the function of the safety valve for the heating circuit
- The air intake and exhaust openings must always be free of obstructions and kept clear. Therefore, check for unimpeded air infeed accordingly. Constrictions or even blockages which, for example occur
  - when applying house insulation with polystyrene balls
  - through packaging material (foils, films, cartons etc.)
  - through foliage, snow, icing or similar weather-related deposits
  - through vegetation (bushes, tall grass etc.)

- through air shaft covers (fly protection screens etc.)

and which must be prevented and/or removed immediately

- Check at regular intervals that the condensate can drain out of the device freely, without obstruction. To this end, check the condensate pan in the device and the evaporator regularly for dirt/clogging and clean as necessary. Also check the evaporator from all sides and clean if necessary
- ▶ Either carefully blow out the evaporator with compressed air or rinse it with water without pressure.

### Check evaporator and condensate pan and clean if required

1. Remove the front panel.  
→ "5.3.3 Transport with a handcart", page 9
2. Serviceöffnung Verdampfer (①) und Serviceöffnung Kondensatwanne (②) abnehmen.

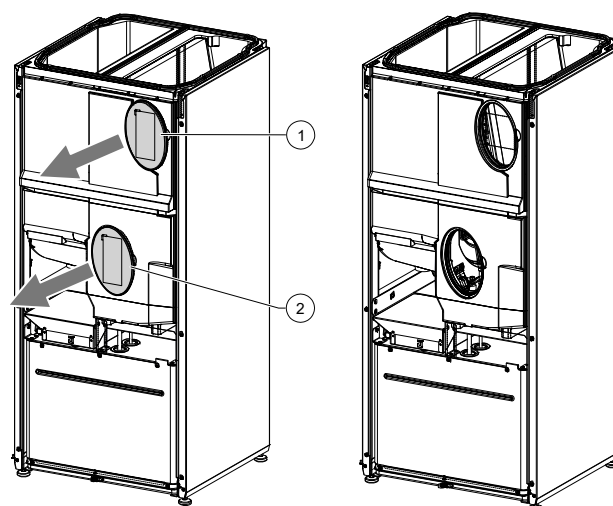

3. The evaporator and the condensate pan can now be inspected and cleaned if necessary.



## 12.4 Clean and flush condenser

- ▶ Clean and flush the condenser in accordance with the manufacturer's instructions.
- ▶ After flushing the condenser with chemical cleaning product: neutralise any residues and flush the condenser thoroughly with water.

## 12.5 Yearly maintenance

- ▶ Record the quality of the heating water analytically. In case of deviations from the specifications, take suitable measures without delay
- ▶ Check all installed dirt traps for dirt and clean them if necessary

## 13 Faults

- ▶ Read out the cause of the fault via the diagnostics program of the heating and heat pump controller.
  - ▶ Contact the local partner of the manufacturer or the factory's customer service. Have the fault message and unit number to hand.
- "Nameplates", page 7

## 14 Dismantling and disposal

- ✓ The disposal equipment is suitable for flammable refrigerants.
- ▶ The locally applicable regulations for handling flammable refrigerants are complied with.
- ▶ Keep away from sources of ignition.
- ▶ Collect all media safely.
- ▶ Separate components according to their materials.

### 14.1 Disposal and recycling

- ▶ Dispose of environmentally hazardous media in accordance with local regulations (e.g. refrigerant, compressor oil).
- ▶ Recycle or ensure proper disposal of unit components and packaging materials in accordance with local regulations.



# Technical data / Scope of supply

# Polaris 4

Performance data				Polaris 4	
Heating capacity   COP	for A10/W35 acc. to DIN EN 14511-x	Partial load operation	kW   COP	3.82	5.03
	for A7/W35 acc. to DIN EN 14511-x	Partial load operation	kW   COP	3.47	4.84
	for A7/W55 acc. to DIN EN 14511-x	Partial load operation	kW   COP	3.24	3.08
	for A2/W35 acc. to DIN EN 14511-x	Partial load operation	kW   COP	2.17	4.02
	for A-7/W35 acc. to DIN EN 14511-x	Full load operation	kW   COP	3.68	3.00
	for A-7/W55 acc. to DIN EN 14511-x	Full load operation	kW   COP	3.42	1.79
Heating capacity	for A10/W35	min.   max.	kW   kW	2.07	4.90
	for A7/W35	min.   max.	kW   kW	2.00	4.30
	for A7/W55	min.   max.	kW   kW	2.11	4.27
	for A2/W35	min.   max.	kW   kW	1.71	4.10
	for A-7/W35	min.   max.	kW   kW	1.13	3.68
	for A-7/W55	min.   max.	kW   kW	1.18	3.42
Cooling capacity   EER	for A35/W18	Partial load operation	kW   EER	3.62	2.85
	for A35/W7	Partial load operation	kW   EER	2.68	2.44
Cooling capacity	for A35/W18	min.   max.	kW   kW	2.72	3.62
	for A35/W7	min.   max.	kW   kW	1.21	2.87
Heating capacity domestic hot water preparation			kW	max 6	
<b>Operating limits</b>					
Heating circuit return min.   Heating circuit flow max. Heating		within heat source min./max.	°C	20	45
Heat source, heating		min.   max.	°C	-22	35
Additional operating points			...	A-2 / W60	
<b>Installation location (only valid for indoor installation)</b>					
Room temperature		min.   max.	°C	5   35	
Relative humidity maximum (non-condensing)			%	60	
<b>Sound</b>					
Sound power level inside		min.   Night   max.	dB(A)	42	48   49
Sound power level outside <sup>1)</sup> combined		min.   Night   max.	dB(A)	34	45   48
Sound power level outside <sup>1)</sup> Air inlet		min.   Night   max.	dB(A)	30	41   44
Sound power level outside <sup>1)</sup> Air outlet		min.   Night   max.	dB(A)	31	42   45
Sound power level acc. to DIN EN 12102-1		inside   outside	dB(A)	43   41	
Tonality   Low-frequency			dB(A)   • yes – no	–   –	
<b>Heat source</b>					
Air flow rate at maximum external pressing   Maximum external pressure			m <sup>3</sup> /h   Pa	1200   25	
<b>Heating circuit</b>					
Flow rate (pipe dimensioning)   Min. volume buffer tank in series   Min. volume separation buffer tank			l/h   l   l	1200   60   100	
Free pressing   Pressure loss   Flow rate			bar   bar   l/h	–   0.03   1200	
Max. allowable operating pressure			bar	3	
Circulation pump control range			l/h	–   –	
<b>General unit data</b>					
Data of the standards according to version			EN14511-x   DIN EN 12102-1	2018   2018	
Total weight			kg	116	
Weight of heat pump module   Compact module   Fan module			kg   kg   kg	–   –   –	
Refrigerant type   Refrigerant capacity			...   kg	R454B   1.64	
<b>Electrics</b>					
Voltage code   all-pole fuse protection for heat pump *)**			...   A	1-N/PE/230V/50Hz   C10	
Voltage code   Control voltage fuse protection **)			...   A	1-N/PE/230V/50Hz   B10	
Voltage code   Electric heating element fuse protection **)			1 phase	...   A	
Voltage code   Electric heating element fuse protection **)			3 phases	...   A	
HP*): effect. power consumption A7/W35 (partial load operation) DIN EN 14511-x   Electric consumption I cosφ			kW   A   ...	0.79   2.56   0.9	
HP*): effective power consumption A7/W35 acc. to DIN EN 14511-x: min.   max.			kW   kW	0.25   2.10	
HP*): max. machine current   max. power consumption within the operating limits			A   kW	16   2.22	
Starting current: direct   with soft starter			A   A	< 5   –	
Degree of protection			IP	20	
Zmax			Ω	–	
Residual current circuit breaker			if required	type B	
Electric heating element output			3   2   1 phase	kW   kW   kW	
Circulation pump power consumption, heating circuit			min.   max.	W	
<b>Other unit information</b>					
Safety valve heating circuit   Response pressure		included in scope of supply: • yes – no   bar		–   –	
Buffer tank   Volume		included in scope of supply: • yes – no   l		–   –	
Heating circuit expansion vessel   Volume   Prepressure		incl. in scope of supply: • yes – no   l   bar		–   –	
Overflow valve   Changeover valve, heating - domestic hot water		integrated: • yes – no		–	
Heating circuit vibration decoupling		incl. in scope of supply or integrated: • yes – no		•	
Controller   Heat quantity recording   Extension board		incl. in scope of supply or integrated: • yes – no		–   •   –	

\*) compressor only, \*\*) note local regulations 1) Indoor and outdoor installation.  
 For indoor installation 8kW and 12kW: Intake 1.5m air duct, Blow-out 1.5m air duct + air duct bend (original accessories)  
 For indoor installation 4kW: Intake 4m air duct hose, Blow-out 4m air duct hose (original accessories)  
 The performance data and the operating limits apply to clean heat exchangers | Index: |

813647



# Polaris 4

## Performance curves / operating limits / heating

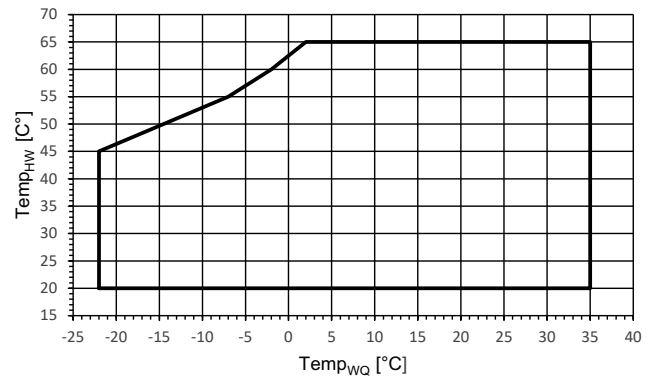
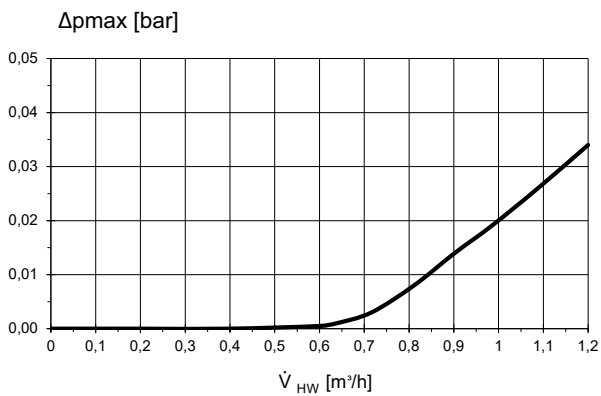
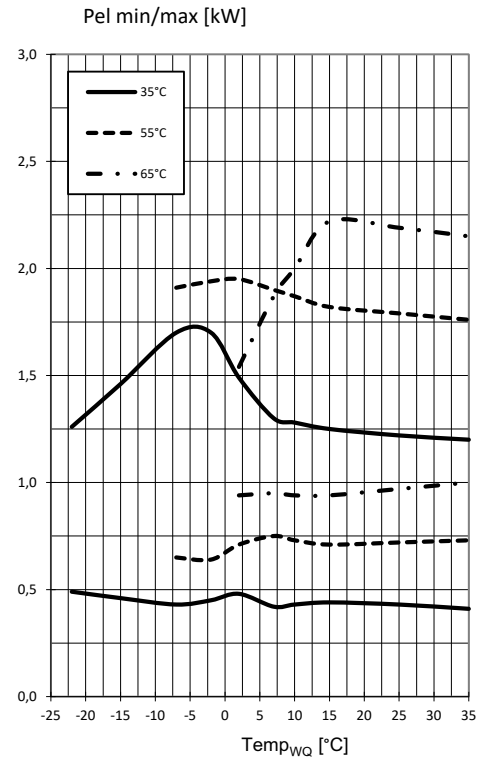
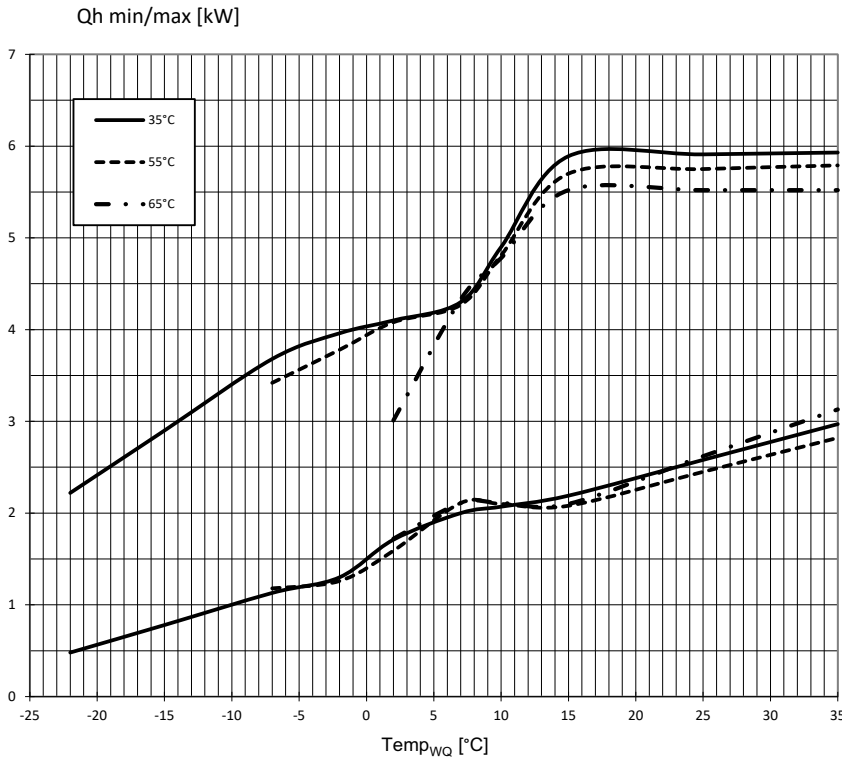

823292 d

Key: 823327

$\dot{V}_{HW}$	Volume flow rate heating water
Temp <sub>WQ</sub>	Heat source temperature
Δpmax	max. free pressing
Qh min/max	min./max. heating power
Pel min/max	min./max. power consumption





# Performance curves / cooling

Polaris 4

Q0 min/max [kW]

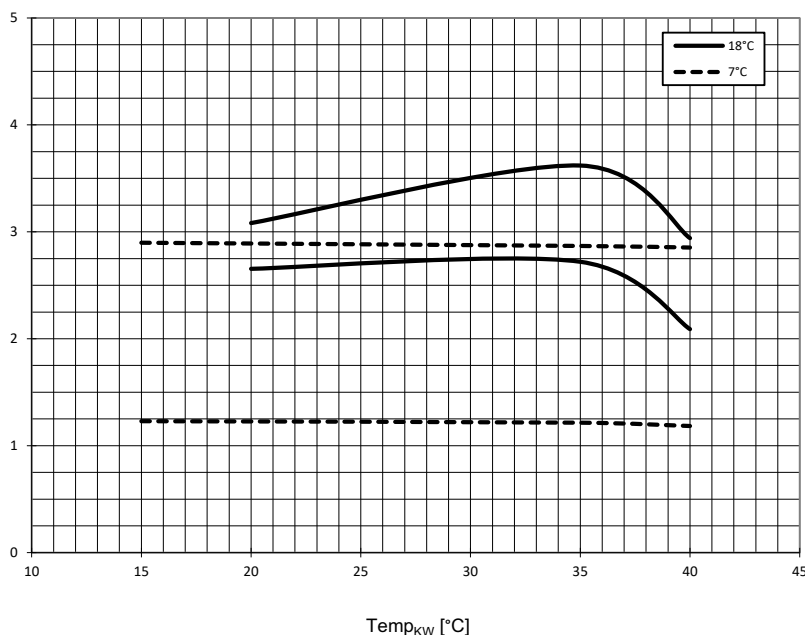

Pel min/max [kW]

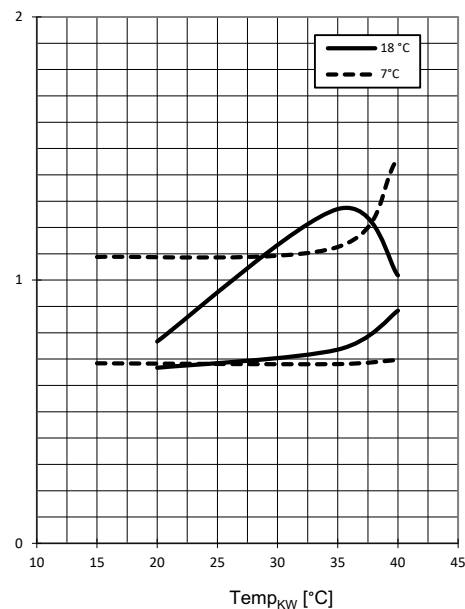

$\Delta p_{max}$  [bar]

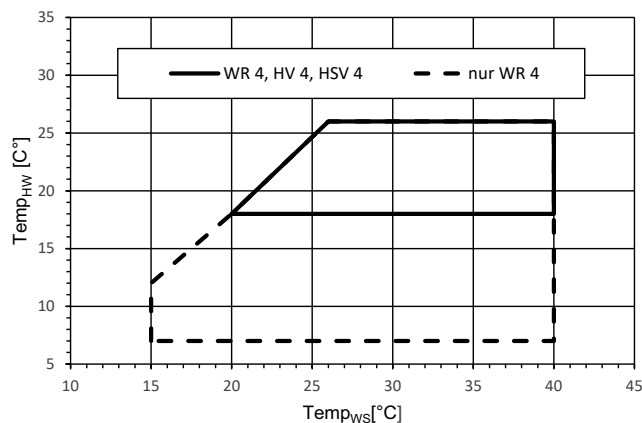
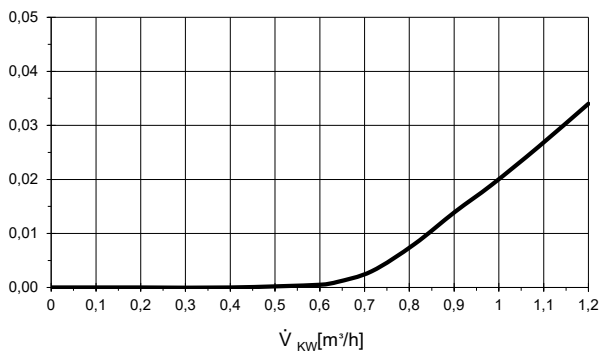

823292 d

Key: 823327

$\dot{V}_{KW}$	Volume flow rate cooling water
Temp <sub>WS</sub>	Heat sink temperature
$\Delta p_{max}$	max. free pressing
Q0 min/max	min./max. cooling capacity
Pel min/max	min./max. power consumption



# Polaris 4

# Dimensional drawings

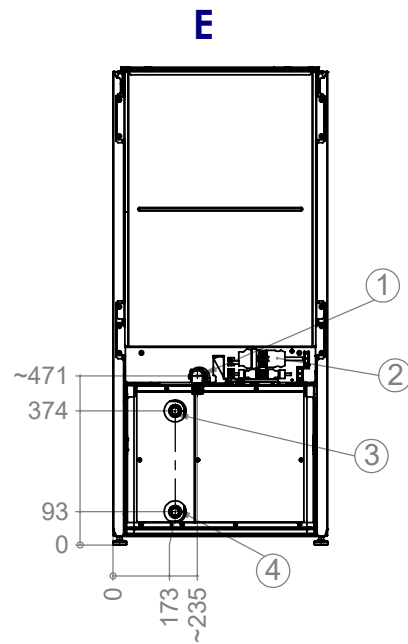
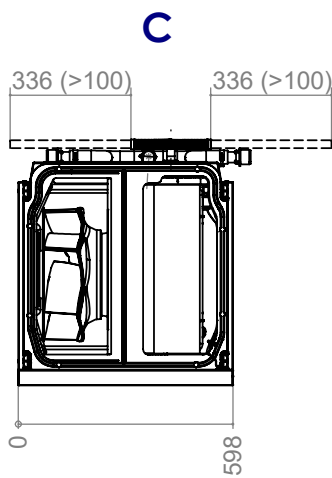
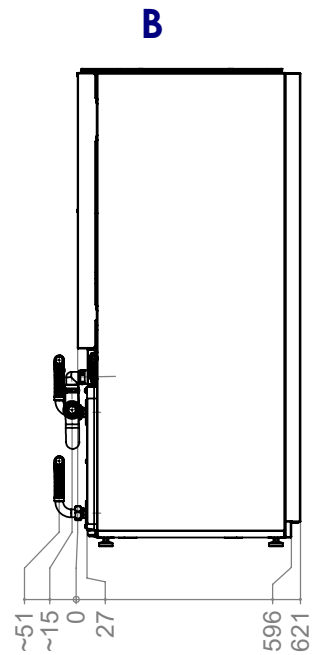
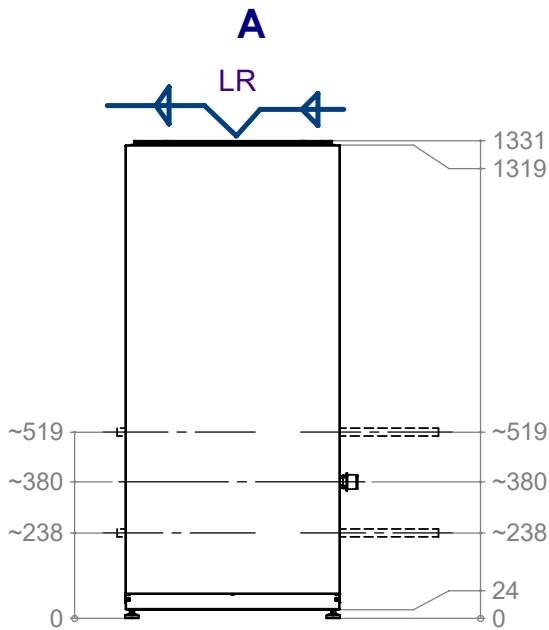

Key: UK819531

All dimensions in mm.

Pos.	Name
A	Front view
B	Side view from left
C	Top view
E	Rear view without piping
LR	Air direction

Pos.	Name	
1	Connection condensate water	Connection to HT pipe DN 40
2	Connection electrics	
3	Heating water outlet (flow)	G 1" External thread
4	Heating water inlet (return)	G 1" External thread



# Installation plan V1

Polaris 4

## V1

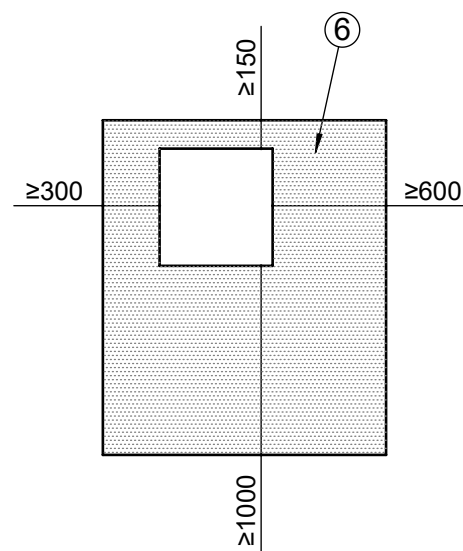
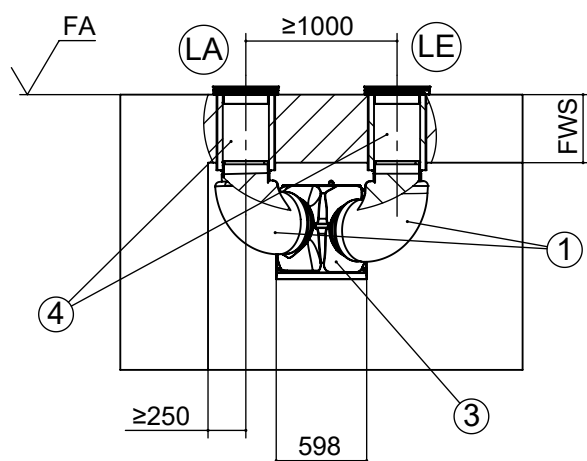
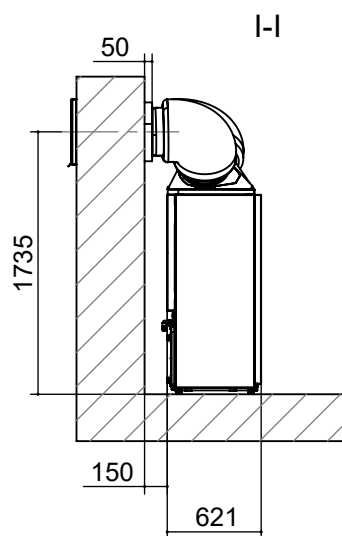
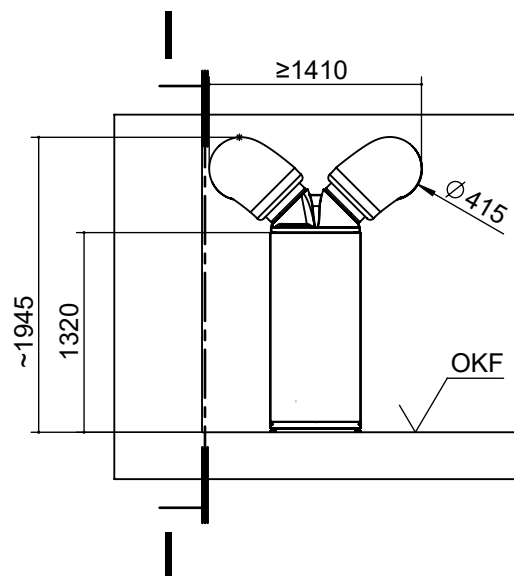

### NOTE

The installation plans V1 – V5 represent only a selection of possible installations. Depending on the installation situation, for example, other lengths of the air duct hoses must be used.

- Operating manual of the flexible air duct system ADH
- ▶ Always maintain the minimum clearances for the heat pump.

Key: UK819532b-1

All dimensions in mm.

V1 | Version 1

Pos. | Name

FWS | Finished wall thickness  $\leq 450$  mm

OKF | Top edge of the finished floor

LA | Air outlet

LE | Air inlet

Pos. | Name

1 | Accessory: Air duct hose ADH 315-1000

3 | Accessory: EPP-adapter Dual-Tube ADT

4 | Accessory: Wall duct WD

6 | Minimum clearance for service purposes

Quantity

2

1

2



V1.1

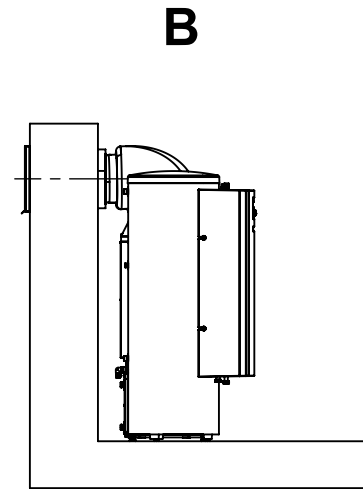
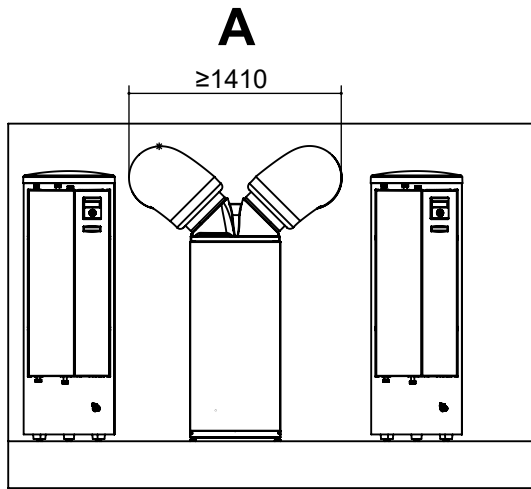

C1

C2

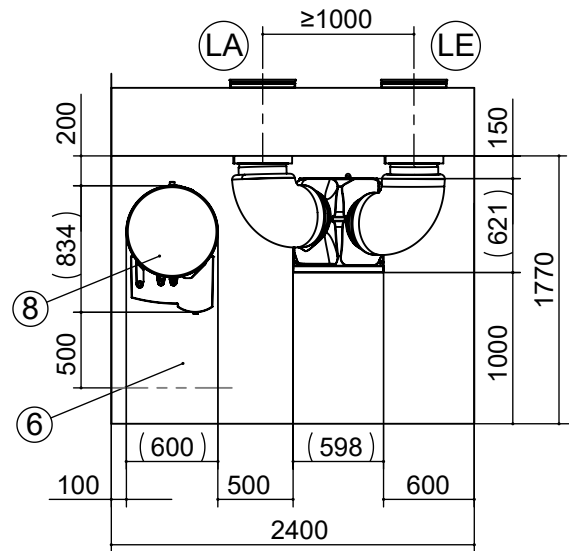
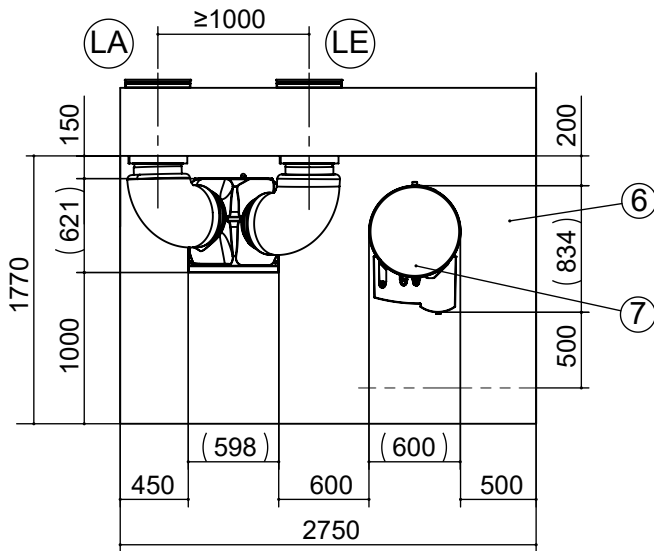

Key: UK819532b-1.1  
All dimensions in mm.

V1.1	Version 1.1
Pos.	Name
A	Front view
B	Side view from left
C1	Top view, HSV 4 right
C2	Top view, HSV 4 left
LA	Air outlet
LE	Air inlet

Pos.	Name	Quantity
6	Minimum clearance for service purposes	
7	Hydraulic station HSV 4 to the right of the unit	1
8	Hydraulic station HSV 4 to the left of the unit	1



# V1.2

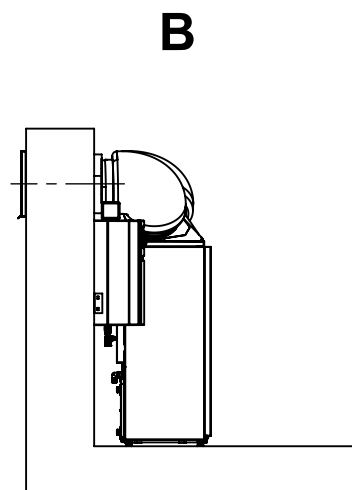
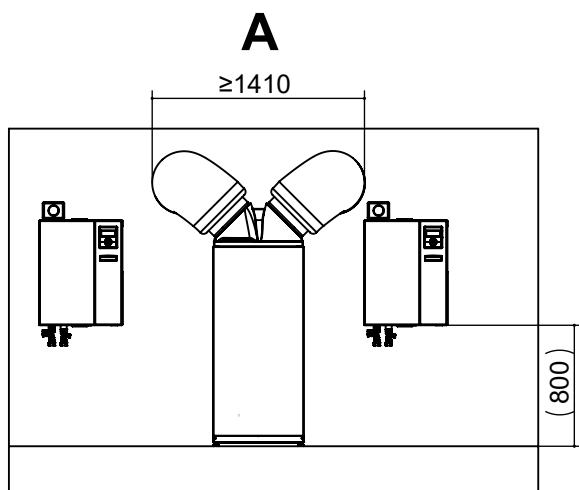

## C1

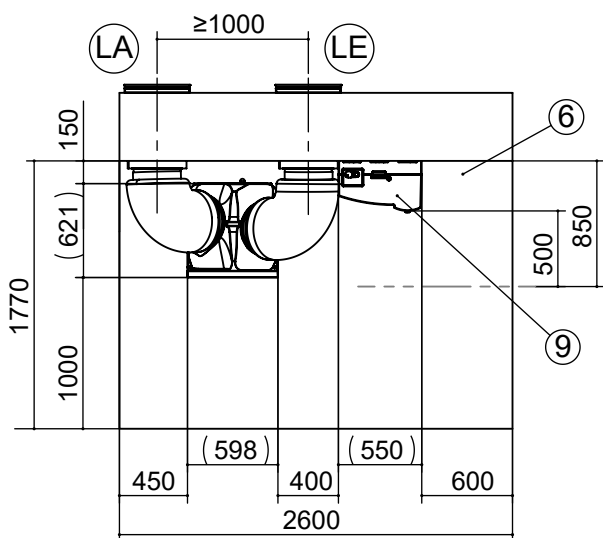

## C2

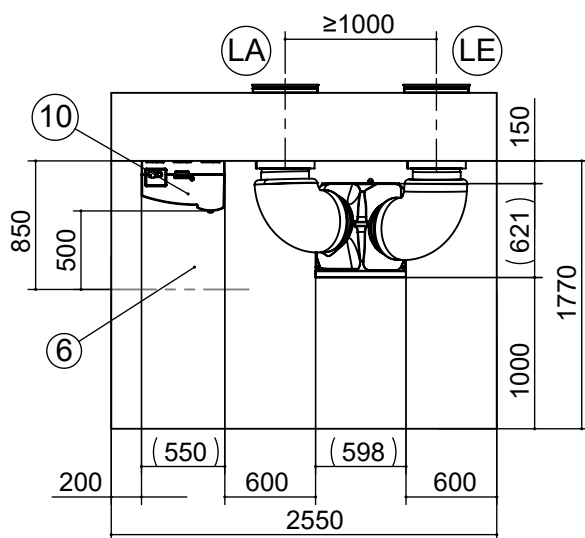

Key: UK819532b-1.2  
 All dimensions in mm.

V1.2 | Version 1.2

Pos.	Name
A	Front view
B	Side view from left
C1	Top view, HV 4 right
C2	Top view, HV 4 left
LA	Air outlet
LE	Air inlet

Pos.	Name	Quantity
6	Minimum clearance for service purposes	
9	Hydraulic module HV 4 to the right of the unit	1
10	Hydraulic module HV 4 to the left of the unit	1



# Polaris 4

# Installation plan V2

## V2

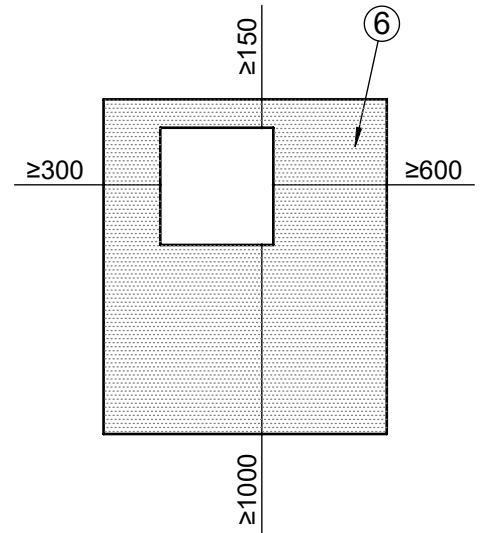
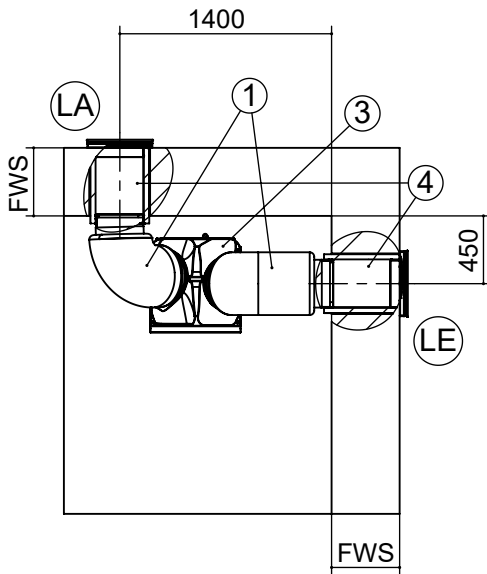
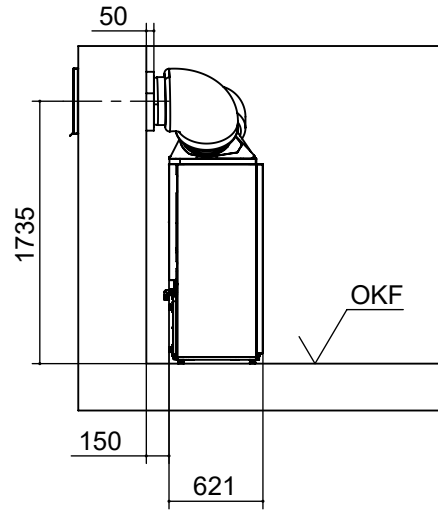
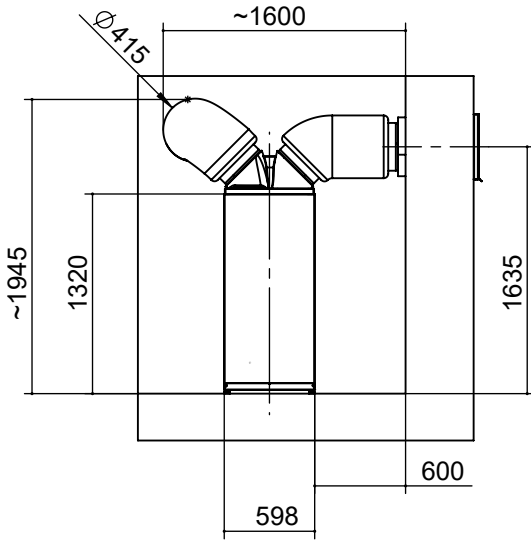

Key: UK819532b-2  
All dimensions in mm.

V2	Version 2
Pos.	Name
FWS	Finished wall thickness ≤ 450 mm
OKF	Top edge of the finished floor
LA	Air outlet
LE	Air inlet

Pos.	Name	Quantity
1	Accessory: Air duct hose ADH 315-1000	1
3	Accessory: EPP-adapter Dual-Tube ADT	1
4	Accessory: Wall duct WD	2
6	Minimum clearance for service purposes	



# Installation plan V3

Polaris 4

## V3

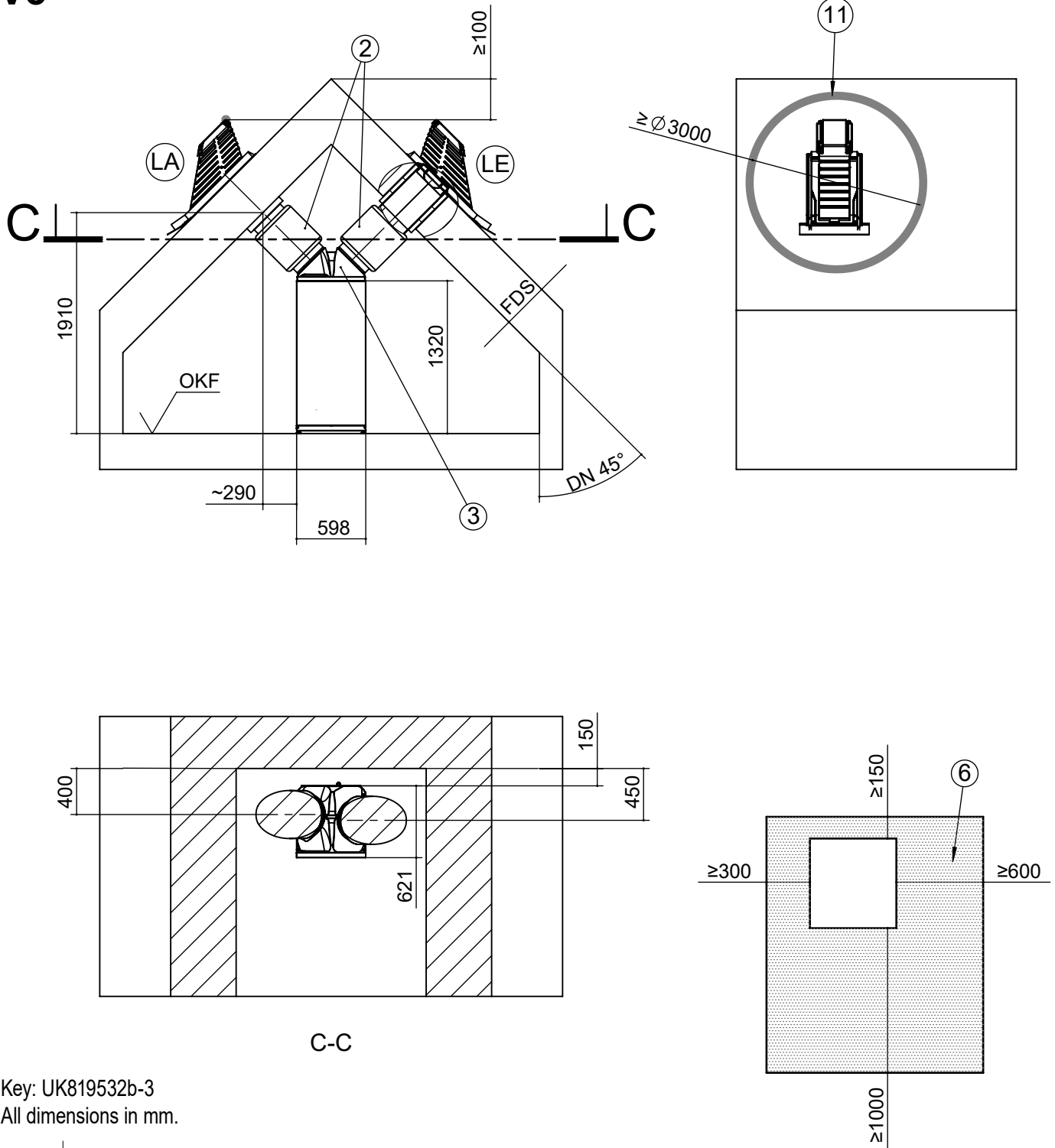

Key: UK819532b-3  
All dimensions in mm.

V3	Version 3
Pos.	Name
C-C	Section top view
DN	Roof pitch
FDS	Finished roof thickness $\leq 450$ mm
OKF	Top edge of the finished floor
LA	Air outlet
LE	Air inlet

Pos.	Name	Quantity
2	Accessory: Air duct hose ADH 315-1000	2
3	Accessory: EPP-adapter Dual-Tube ADT	1
5	Accessory: Roof duct WD	2
6	Minimum clearance for service purposes	
11	Minimum clearance to air-bearing components (e.g. chimneys, vents)	



# Polaris 4

# Installation plan V4

## V4

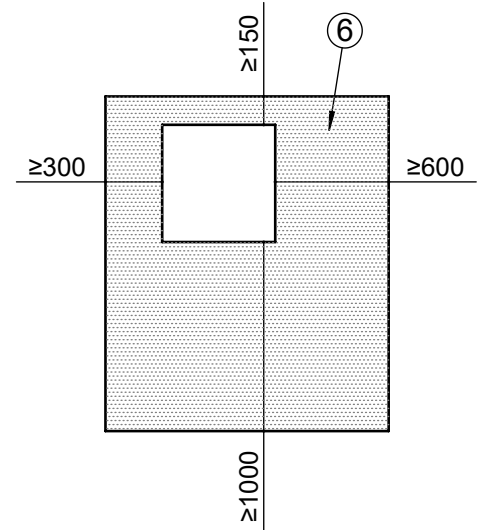
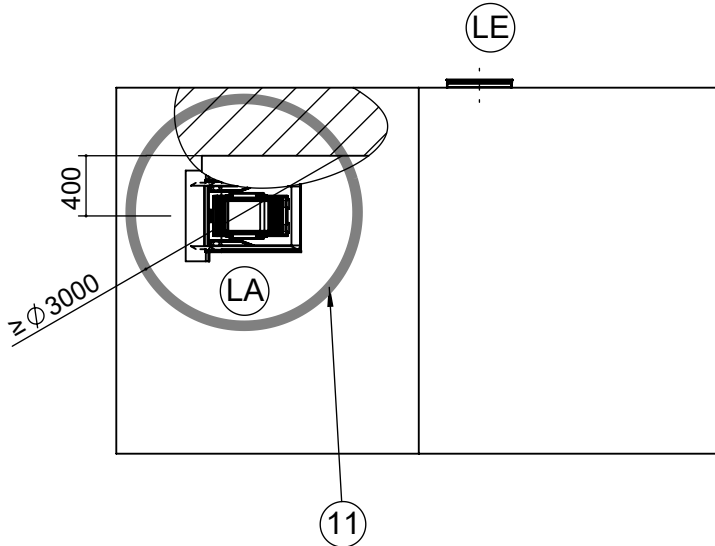
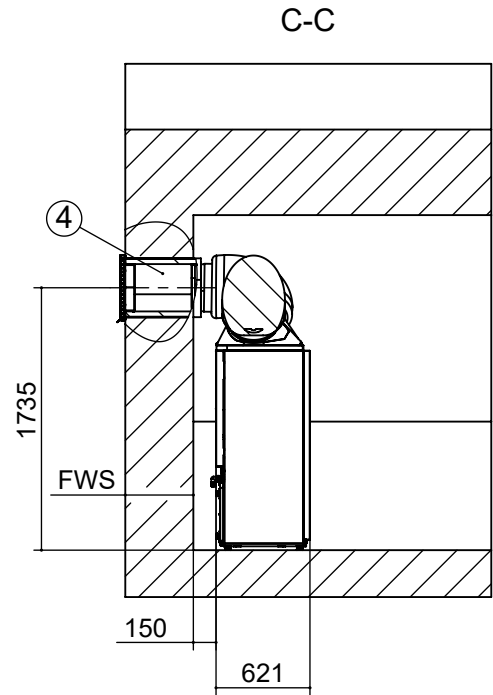
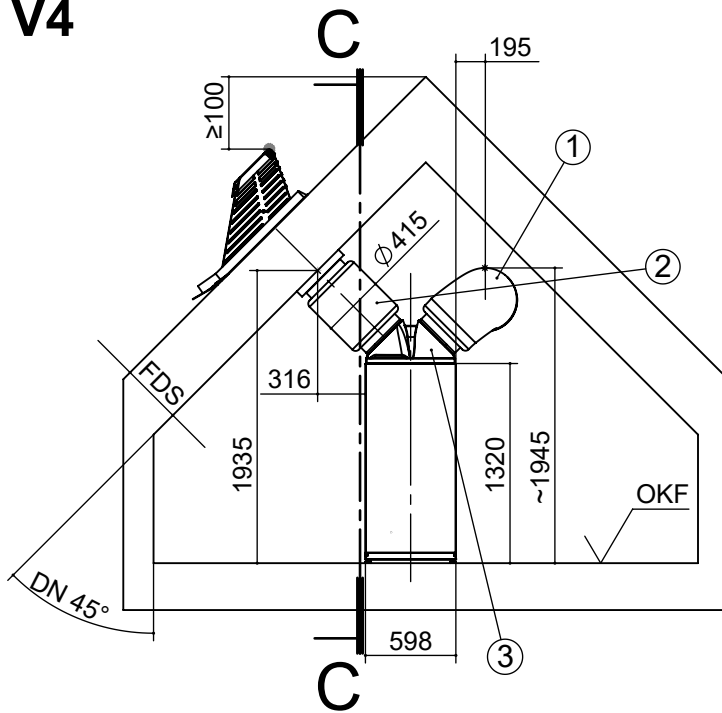

Key: UK819532b-4  
All dimensions in mm.

V4	Version 4
Pos.	Name
C-C	Section side view from left
DN	Roof pitch
FDS	Finished roof thickness ≤ 450 mm
FWS	Finished wall thickness ≤ 450 mm
OKF	Top edge of the finished floor
LA	Air outlet
LE	Air inlet

Pos.	Name	Quantity
1	Accessory: Air duct hose ADH 315-1000	1
2	Accessory: Air duct hose ADH 315-500	1
3	Zubehör: EPP-Adapter Dual-Tube ADT	1
4	Accessory: Wall duct WD	1
5	Accessory: Roof duct RD	1
6	Minimum clearance for service purposes	
11	Minimum clearance to air-bearing components (e.g. chimneys, vents)	





# Installation plan V5

# Polaris 4

## V5

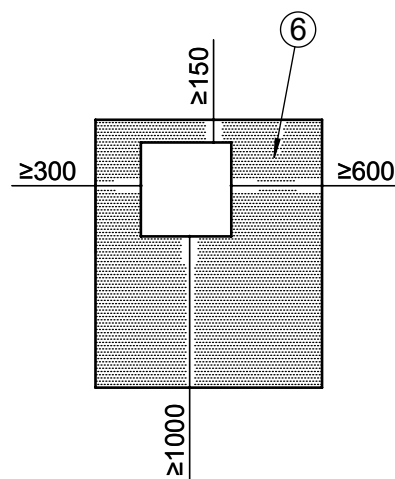
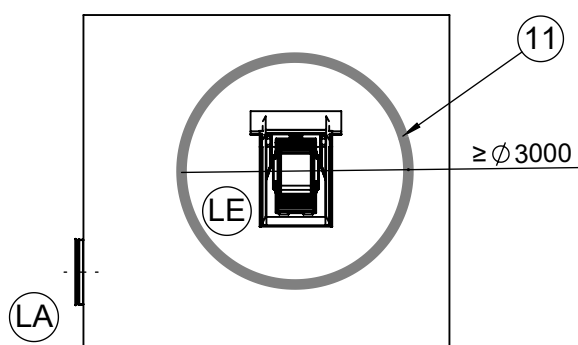
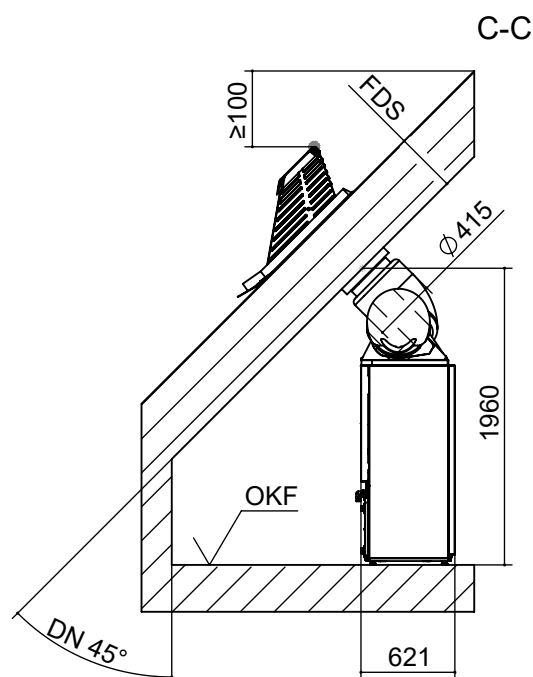
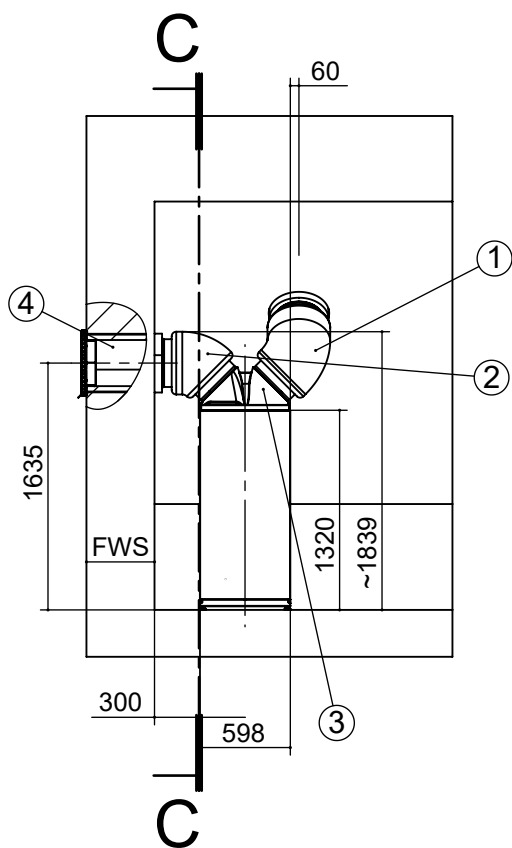

Key: UK819532b-5  
All dimensions in mm.

V5	Version 5
Pos.	Name
C-C	Section side view from left
DN	Roof pitch
FDS	Finished roof thickness ≤ 450 mm
FWS	Finished wall thickness ≤ 450 mm
OKF	Top edge of the finished floor
LA	Air outlet
LE	Air inlet

Pos.	Name	Quantity
1	Accessory: Air duct hose ADH 315-1000	1
2	Accessory: Air duct hose ADH 315-500	1
3	Zubehör: EPP-Adapter Dual-Tube ADT	1
4	Accessory: Wall duct WD	1
5	Accessory: Roof duct RD	1
6	Minimum clearance for service purposes	
11	Minimum clearance to air-bearing components (e.g. chimneys, vents)	



V6

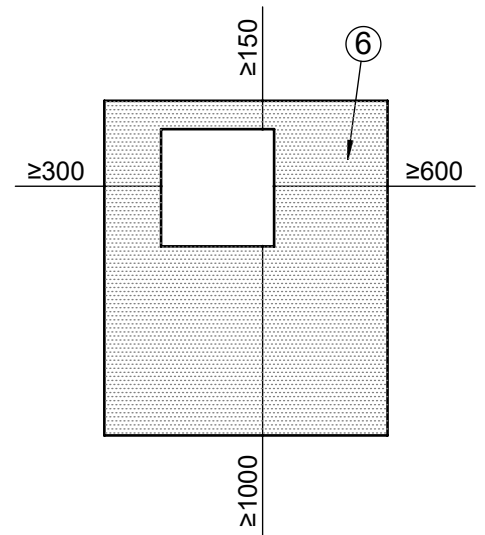
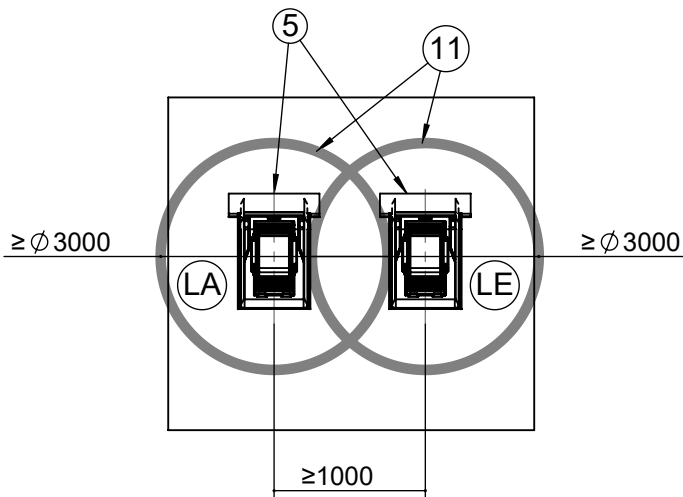
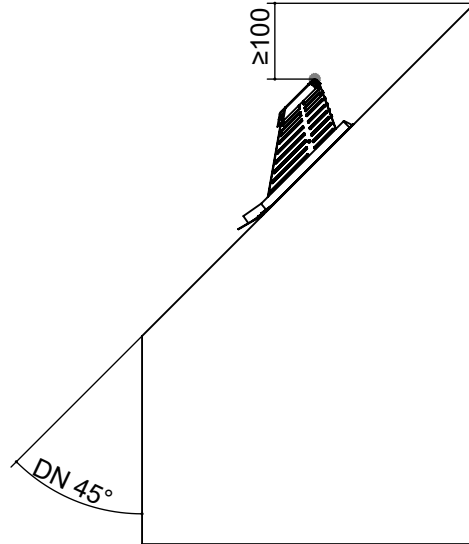
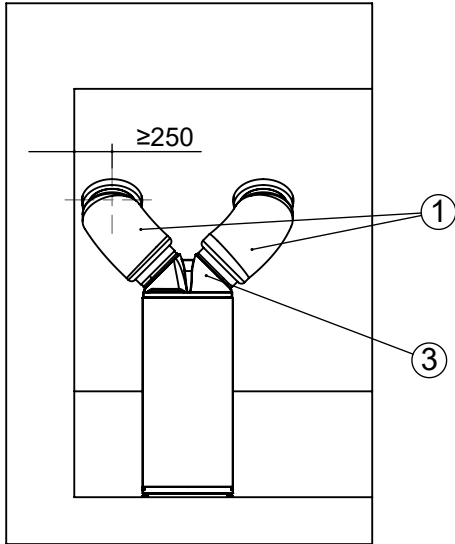

Key: UK819532b-6  
All dimensions in mm.

V6	Version 6
Pos.	Name
DN	Roof pitch
LA	Air outlet
LE	Air inlet

Pos.	Name	Quantity
1	Accessory: Air duct hose ADH 315-1000	2
3	Accessory: EPP-Adapter Dual-Tube ADT	1
5	Accessory: Roof duct RD	2
6	Minimum clearance for service purposes	
11	Minimum clearance to air-bearing components (e.g. chimneys, vents)	



## IMPORTANT

The minimum distances necessary for correct and safe operation as well as any service work must be observed.

- ✓ Air intake on the side facing away from the coast / from the prevailing wind direction
- ✓ Air outlet not on the side facing the coast / prevailing wind direction

For air ducting with wall ducts WD

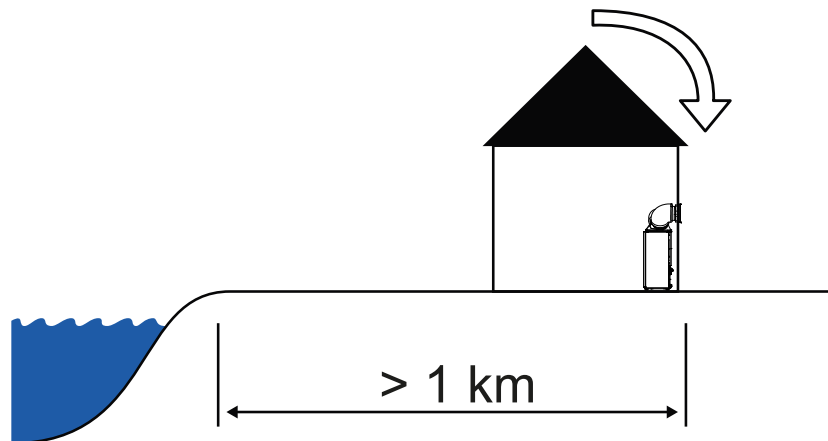

For air ducting with roof duct RD

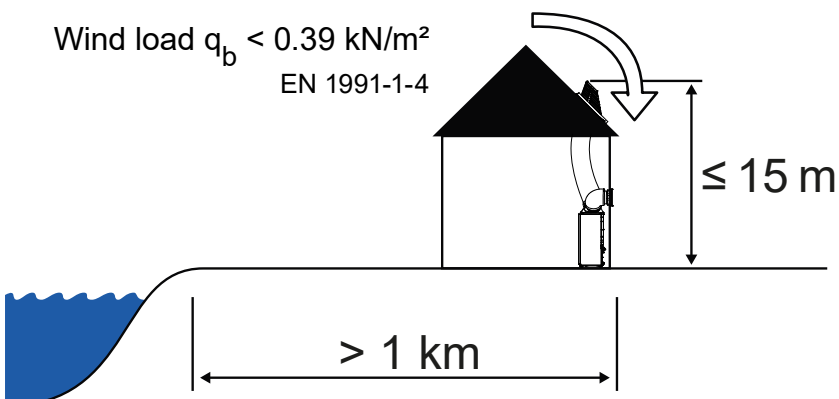
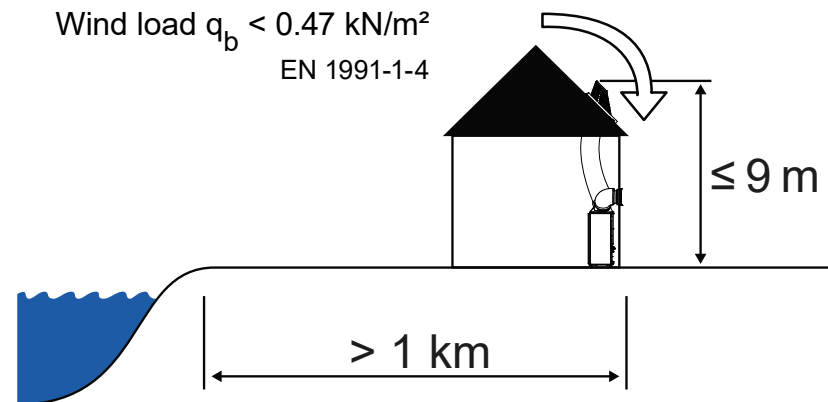

→ Installation instructions Flexible Air Duct System ADH



# Polaris 4 with hydraulic station HSV4

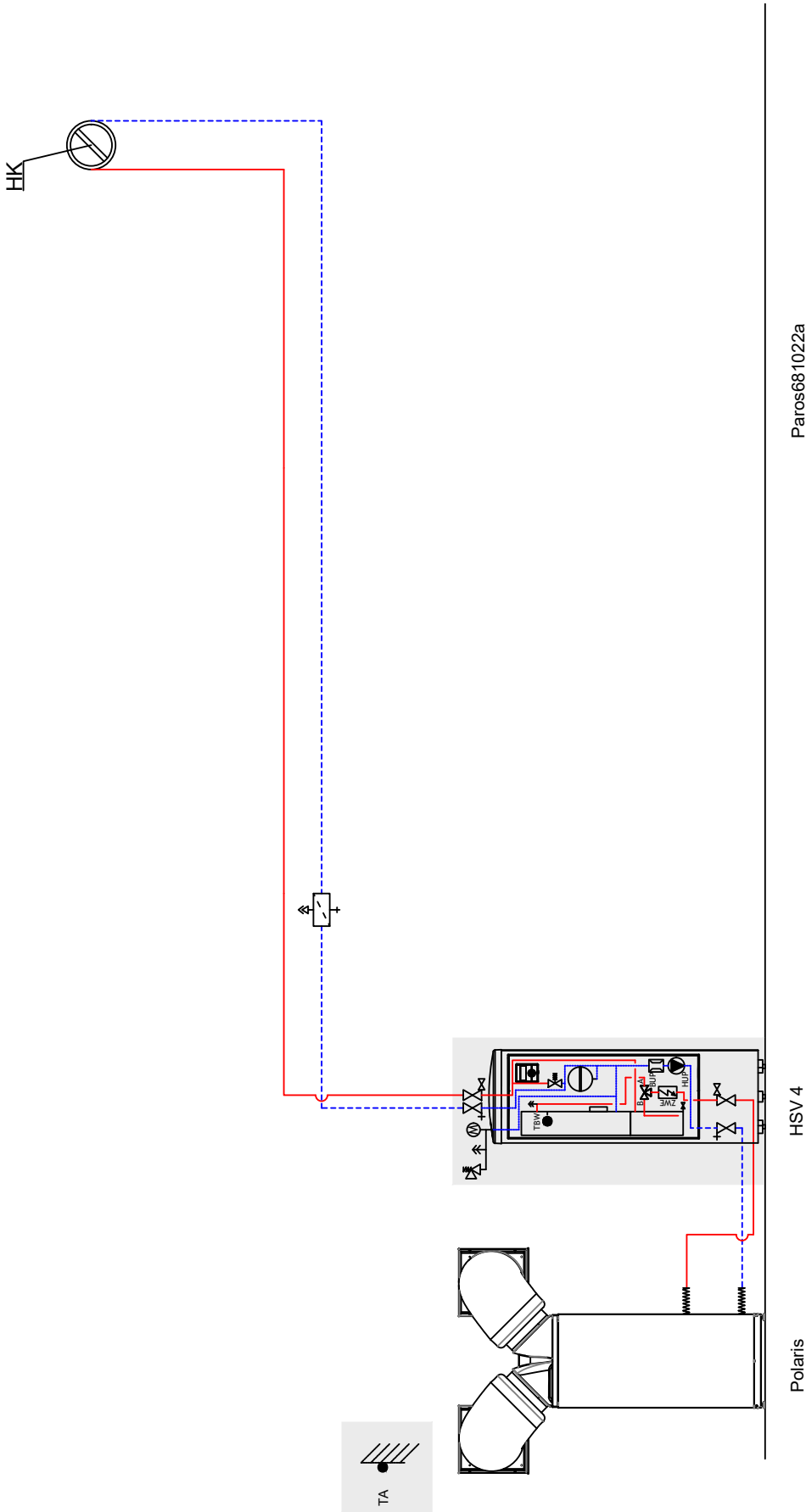

**NOTE** This schematic diagram is an example of a system without shut-off and safety devices, and it does not replace the technical planning and design on site. All regional standards, laws and regulations must be observed. The pipe dimensions must be carefully planned and designed.





# Polaris 4 with hydraulic module HV4 and buffer tank in series

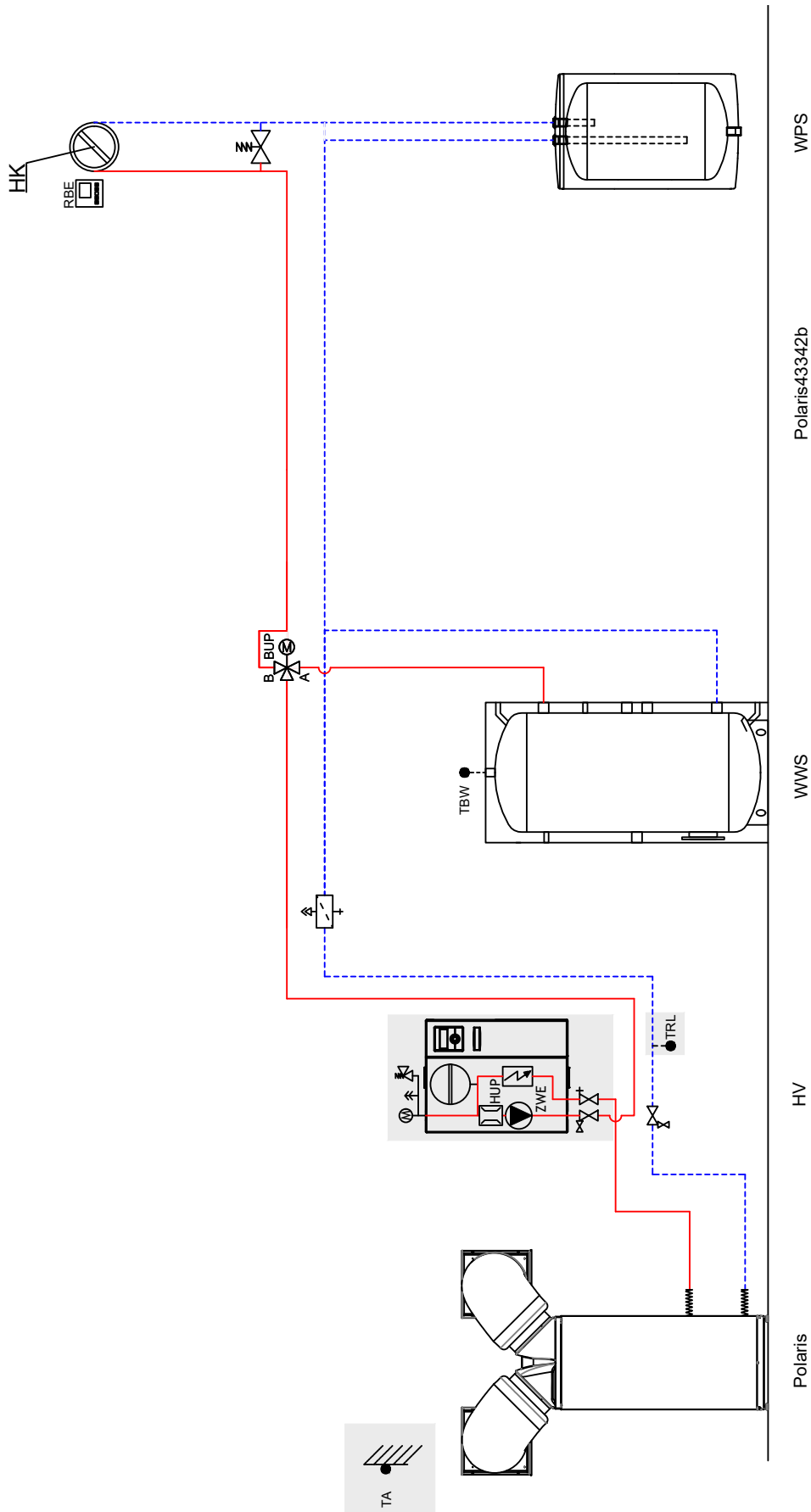

**NOTE** This schematic diagram is an example of a system without shut-off and safety devices, and it does not replace the technical planning and design on site. All regional standards, laws and regulations must be observed. The pipe dimensions must be carefully planned and designed.







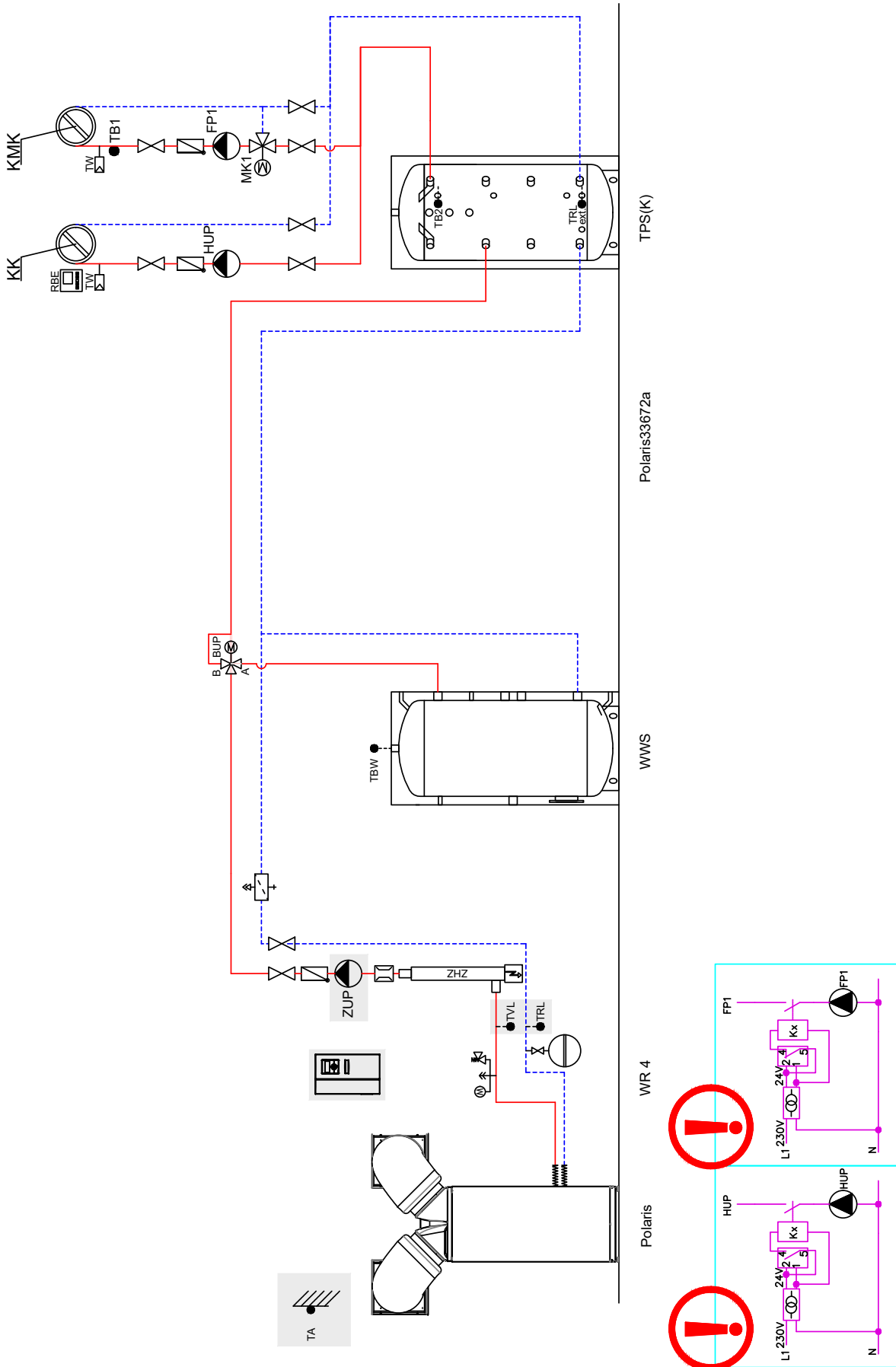





























































# Polaris 4 with wall-mounted controller WR 4 and separation tank



## NOTE

This schematic diagram is an example of a system without shut-off and safety devices, and it does not replace the technical planning and design on site. All regional standards, laws and regulations must be observed. The pipe dimensions must be carefully planned and designed.



	Vibration isolation		Gas- or oil-boiler
	Shut-off device and drainage		Wood boiler
	Shut-off device with dirt trap		Brine pressure switch
	Safety group		Swimming pool heat exchanger
	Shut-off device		Separation heat exchanger / intermediate heat exchanger
	Circulation pump		Solar domestic hot water tank
	Non return valve / one way valve		Pipe lead-in
	Overflow valve		Fresh water station (TWS)
	Membrane expansion vessel		Room control unit
	Second heat generator (ZWE)		Dew-point monitor
	3-way mixing valve / switching valve		Supply heat pump
	4-way mixing valve / switching valve		Circulation pump / switching valve domestic hot water
	Dirt-trap		Mixer circuit 1/2/3 (heating or cooling function)
	Wall breakthrough		Circulation pump heating circuit
	Brine manifold		Circulation pump / switching valve
	Ground slinkies		Feed circulating pump
	Ground collector		Circulation pump
	Flow switch		Domestic hot water charging pump
	Groundwater spring pump with flow direction groundwater		Heat source circulation pump
	Buffer tank:		Outdoor temperature sensor
	- TPS Stratified storage tank		Sensor domestic hot water
	- RPS Series buffer tank		Sensor mixer circuit
	- TPSK Stratified storage tank (cooling)		Sensor external return
	- WTPSK Stratified storage tank, wall-mounted (cooling)		Sensor return
	Multifunction tank		Flow sensor
	Domestic hot water tank		Sensor desuperheater
	Volume flow meter		Heating circuit
	Heat meter		Heating mixing circuit
			Cooling circuit
			Cooling mixing circuit
			Safety package primary
			Safety package secondary
			Circulation pump desuperheater
			Controls supplied by customer
			Ent.
			101

<b>Split:</b>	Switching valve domestic hot water / heating
QN10	Switching valve cooling / heating
QN12	Mixing valve additional heating
QN11	Circulation pump
GP12	Outdoor temperature sensor
BT1	upper domestic hot water (displayed value)
BT7	Sensor return
BT3	Sensor domestic hot water
BT6	Flow sensor cooling
BT64	Temperature sensor, liquid state
BT15	Flow temperature heating
BT25	Return temperature heating / cooling
BT71	Sensor heating boiler
BT52	Room temperature sensor
BT50	Flow heating
XL1	Return heating / cooling
XL2	Cold water
XL3	Domestic hot water
XL4	Circulation
XL5	Flow cooling
XI10	Liquid refrigerant
XL13	Gaseous refrigerant
XL14	Flow second heat generator
XL18	Return second heat generator
XL19	Terminal second heat generator
X2	Expansion board Split
EP Split	(not included in scope of delivery)

Controls supplied by customer / on-site components:  
 Parts and components shown in the colour "grey" must be provided by the customer and also operated with a regulation provided by the customer.  
 The temperature difference control SLP of the additional board is excepted from this.

**General:**  
 Pipes, fittings and fixtures must be designed and insulated in accordance with the current and valid standards, guidelines and recognised rules of technology (e.g.: vapour diffusion-tight insulation if the temperature falls below the dew point).







# Circuit diagram 2/5

# Polaris 4

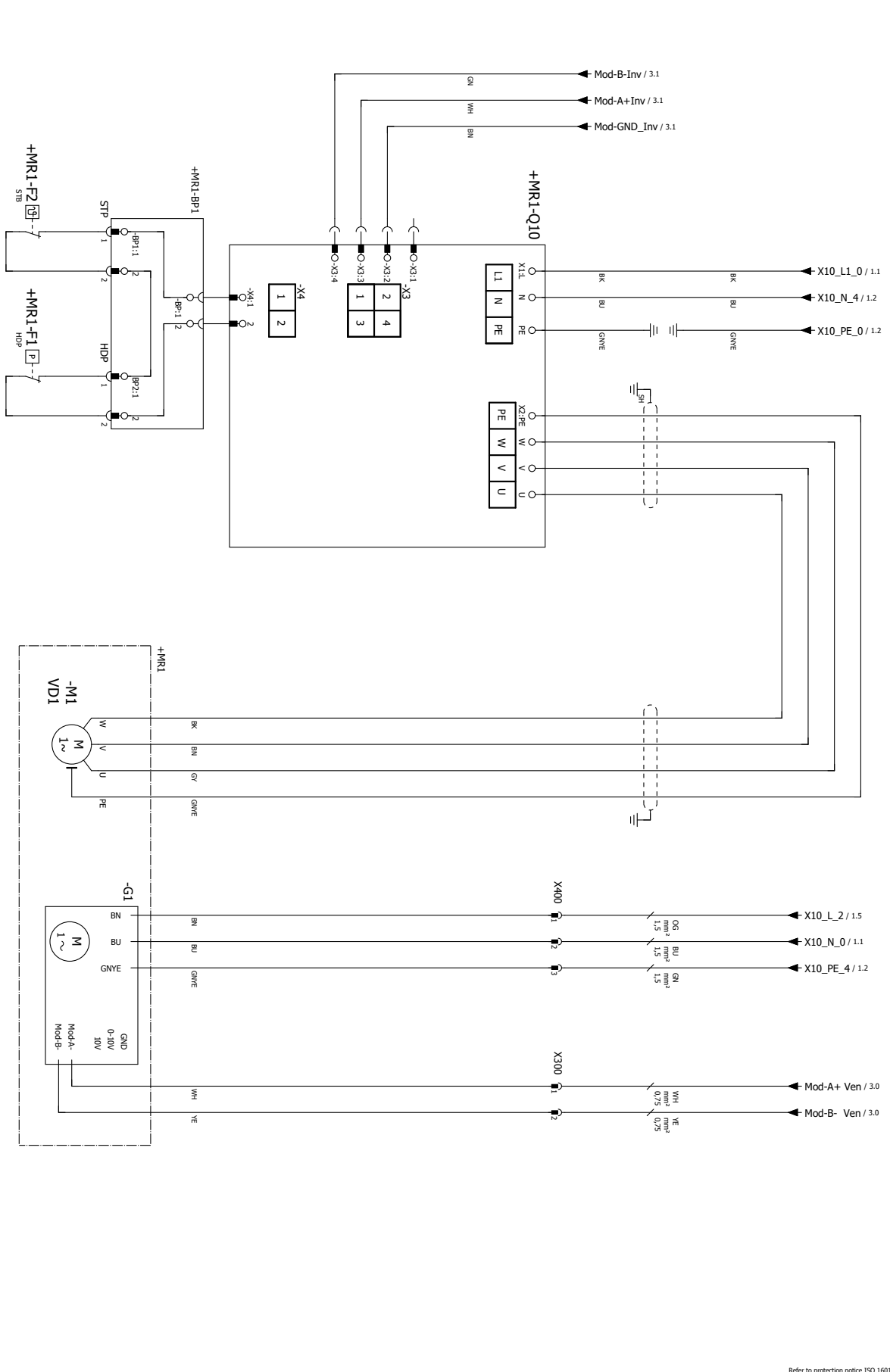

Refer to protection notice ISO 16016.





# Circuit diagram 4/5

# Polaris 4

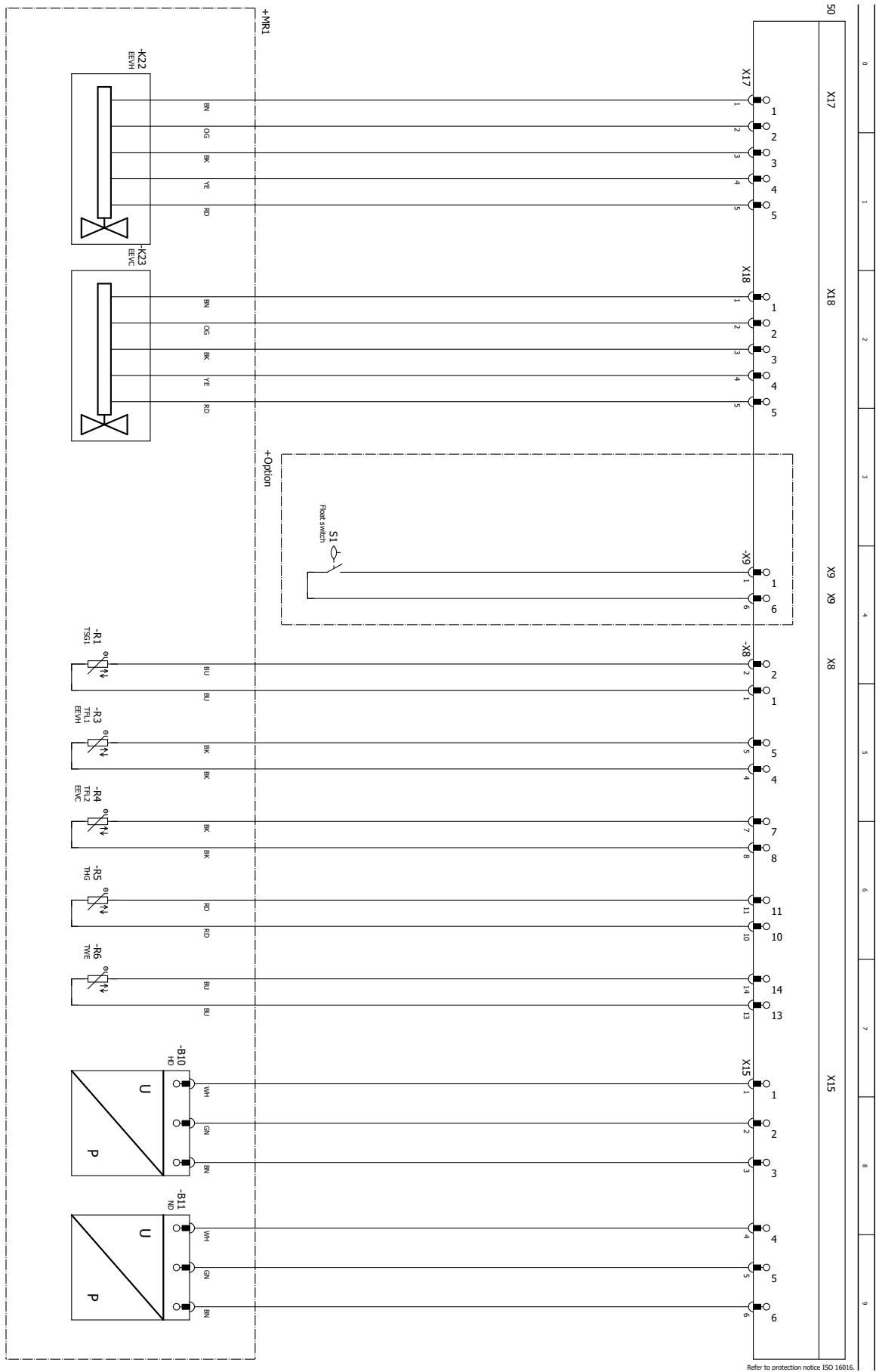











# NOVELAN



**NOVELAN**

**ait-deutschland GmbH**

Industriestraße 3 · 95359 Kasendorf

T +49 9228 / 99 607 - 0

F +49 9228 / 99 607 - 1099

[info@novelan.com](mailto:info@novelan.com)

[www.novelan.com](http://www.novelan.com)

**An ait-deutschland GmbH brand**

Subject to technical amendments without prior notice.

[www.novelan.com](http://www.novelan.com)